

USER MANUAL



SHOOT WOW!
SHARE NOW!



NX500

ENG This user manual includes detailed usage instructions for your camera. Please read this manual thoroughly.

Copyright information

- Microsoft Windows and the Windows logo are registered trademarks of the Microsoft Corporation.
- Mac and Apple App Store are registered trademarks of the Apple Corporation.
- Google Play Store is a registered trademark of Google, Inc.
- SD™, SDHC™, and SDXC™ are registered trademarks of the SD Association.
- HDMI, the HDMI logo, and the term “High Definition Multimedia Interface” are trademarks or registered trademarks of HDMI Licensing LLC.
- Bluetooth® is a registered trademark of Bluetooth SIG, Inc. worldwide.
- Wi-Fi®, the Wi-Fi CERTIFIED logo, and the Wi-Fi logo are registered trademarks of the Wi-Fi Alliance.
- Trademarks and trade names used in this manual are the property of their respective owners.



- Camera specifications or contents of this manual may be changed without prior notice due to upgrade of camera functions.
- You are not allowed to reuse or distribute any part of this manual without prior permission.
- We recommend using your camera within the country where you purchase it.
- Use this camera responsibly and adhere to all laws and regulations concerning its use.

Health and safety information

Always comply with the following precautions and usage tips to avoid dangerous situations and ensure peak performance of your camera.



Warning—situations that could cause injury to yourself or others

Do not disassemble or attempt to repair your camera.

You can damage the camera and expose yourself to the risk of an electric shock.

Do not use your camera near flammable or explosive gases and liquids.

This may cause a fire or explosion.

Do not insert flammable materials into the camera or store these materials near the camera.

This may cause a fire or electric shock.

Do not handle your camera with wet hands.

This may result in an electric shock.

Prevent damage to subjects' eyesight.

Do not use the flash in close proximity (closer than 1 m/3 ft) to people or animals. If you use the flash too close to your subject's eyes, this can cause temporary or permanent eyesight damage.

Keep your camera away from small children and pets.

Keep your camera and all accessories out of the reach of small children and animals. Small parts may cause choking or serious injury if swallowed. Moving parts and accessories may present physical dangers as well.

Do not expose the camera to direct sunlight or high temperatures for an extended period of time.

Prolonged exposure to sunlight or extreme temperatures can cause permanent damage to your camera's internal components.

Avoid covering the camera or charger with blankets or clothes.

The camera may overheat, which may distort the camera or cause a fire.

Do not handle the power supply cord or the charger during a thunderstorm.

This may result in an electric shock.

If liquid or foreign objects enter your camera, immediately disconnect all power sources, such as the battery or charger, and then contact a Samsung service center.

Comply with any regulations that restrict the use of a camera in a certain area.

- Avoid interference with other electronic devices.
- Turn off the camera when in an aircraft. Your camera can cause interference with aircraft equipment. Follow all airline regulations and turn off your camera when directed by airline personnel.
- Turn off the camera near medical equipment. Your camera can interfere with medical equipment in hospitals or health care facilities. Follow all regulations, posted warnings, and directions from medical personnel.

Avoid interference with pacemakers.

Maintain a safe distance between this camera and all pacemakers to avoid potential interference, as recommended by the manufacturer and research groups. If you have any reason to suspect that your camera is interfering with a pacemaker or other medical device, turn off the camera immediately and contact the manufacturer of the pacemaker or medical device for guidance.



Caution—situations that could cause damage to your camera or other equipment

Remove the batteries from your camera when storing it for an extended period of time.

Installed batteries may leak or corrode over time and cause serious damage to your camera.

Use only authentic, manufacturer-recommended, Lithium-ion replacement batteries. Do not damage or heat the battery.

Inauthentic, damaged, or heated batteries may cause a fire or personal injury.

Use only Samsung-approved batteries, chargers, cables, and accessories.

- Using unauthorized batteries, chargers, cables, or accessories can cause batteries to explode, damage your camera, or cause injury.
- Samsung is not responsible for damage or injuries caused by unapproved batteries, chargers, cables, or accessories.

Use the battery only for its intended purpose.

Misusing the battery may cause a fire or electric shock.

Do not touch the flash while it fires.

The flash is very hot when fired and may burn your skin.

When you use the AC charger, turn off the camera before you disconnect the power to the AC charger.

Failing to do so may result in fire or electric shock.

Disconnect the charger from the wall socket when not in use.

Failing to do so may result in fire or electric shock.

Do not use a damaged power supply cord, plug, or loose outlet when you charge batteries.

This may cause a fire or electric shock.

Do not allow the AC charger to come in contact with the +/- terminals on the battery.

This may cause a fire or electric shock.

Do not drop or subject the camera to strong impacts.

Doing so may damage the screen or external or internal components.

Exercise caution when you connect cables and install batteries and memory cards.

If you force the connectors, improperly connect cables, or improperly install batteries and memory cards, you can damage ports, connectors, and accessories.

Keep cards with magnetic strips away from the camera case.

Information stored on the card may be damaged or erased.

Never use a damaged battery or memory card.

This may result in electric shock or camera malfunction or cause a fire.

Do not place the camera in or near magnetic fields.

Doing so may cause the camera to malfunction.

Do not use the camera if the screen is damaged.

If the glass or acrylic parts are broken, visit a Samsung service center to have the camera repaired.

Check that the camera is operating properly before use.

The manufacturer takes no responsibility for any loss of files or damage that may result from camera malfunction or improper use.

You must plug the small end of the USB cable into your camera.

If the cable is reversed, it may damage your files. The manufacturer is not responsible for any loss of data.

Do not expose the lens to direct sunlight.

This may discolor the image sensor or cause it to malfunction.

If the camera overheats, remove the battery and allow it to cool down.

- Prolonged usage of the camera may overheat the battery and raise the internal temperature of the camera. If the camera stops operating, remove the battery and allow it to cool down.
- High internal temperatures may result in noise in your photos. This is normal and does not affect your camera's overall performance.

Avoid interference with other electronic devices.

Your camera emits radio frequency (RF) signals that may interfere with unshielded or improperly shielded electronic equipment, such as pacemakers, hearing aids, medical devices, and other electronic devices in homes or vehicles. Consult the manufacturers of your electronic devices to solve any interference problems you experience. To prevent unwanted interference, use only Samsung-approved devices or accessories.

Use your camera in the normal position.

Avoid contact with your camera's internal antenna.

Data transference and your responsibilities





- Data transferred via WLAN can be stolen, so avoid transferring sensitive data in public areas or on open networks.
- The camera manufacturer is not liable for any data transfers that infringe on copyrights, trademarks, intellectual property laws, or public decency ordinances.

Bluetooth precautions



- The manufacturer is not responsible for the loss, interception, or misuse of data sent or received via the Bluetooth feature.
- Always ensure that you share and receive data with devices that are trusted and properly secured. If there are obstacles between the devices, the operating distance may be reduced.
- Some devices, especially those that are not tested or approved by the Bluetooth SIG, may be incompatible with your device.
- Do not use the Bluetooth feature for illegal purposes (for example, pirating copies of files or illegally tapping communications for commercial purposes). The manufacturer is not responsible for the repercussion of illegal use of the Bluetooth feature.
- Do not connect to Bluetooth speakers, headphones, or other accessories.

Indications used in this manual

Icons used in this manual

Icon	Function
	Additional information
	Safety warnings and precautions
[]	Camera buttons. For example, [Shutter] represents the shutter button.
()	Page number of related information
→	The order of options or menus you must select to perform a step; for example: Select  → Quality (represents select  , and then Quality).
*	Annotation

Mode indications

Mode	Indication
Auto	
Program	P
Aperture Priority	A
Shutter Priority	S
Manual	M
Custom	C
Samsung Auto Shot	SAS
Smart	

Contents

Tips

Concepts in Photography

Shooting postures	13
Holding the camera	13
Standing photography	13
Crouching photography	14
Using the display	14
Low-angle shot.....	15
High-angle shot.....	15
Aperture	16
Aperture value and the depth of field	17
Shutter speed	18
ISO sensitivity	19
How the aperture setting, shutter speed, and ISO sensitivity control exposure	20
Correlation between focal length, angle, and perspective	21
Depth of field	22
What controls out-of-focus effects?.....	22
DOF preview.....	24
Composition	24
Rule of Thirds.....	24
Photos with two subjects	25
Flash	26
Flash guide number.....	26
Bounce Photography	27

Chapter 1

My Camera

Getting started	29
Unpacking.....	29
Camera layout	30
Using the display	33
Using the Self Shot mode	33
Inserting the battery and memory card	34
Removing the battery and memory card.....	34
Using the memory card adapter.....	35
Charging the battery and turning on your camera	36
Charging the battery.....	36
Turning on your camera	36
Performing the initial setup	37
Selecting functions (options)	39
Using buttons and dials.....	39
Using custom buttons and dials	39
Selecting by touch	40
Using MENU	40
E.g. Selecting the photo size in P mode.....	40
Using the smart panel	42
E.g. Adjust the exposure value in P mode.....	42
Using iFn.....	43
Using the iFn standard function.....	43
Using the iFn plus function	45

Display icons	46
In Shooting mode	46
Capturing photos	46
Recording videos	48
About the level gauge	49
In Playback mode	50
Viewing photos	50
Playing videos	50
Changing the information displayed	51
Viewing the notification panel	52
Lenses	53
Lens layout	53
Locking or unlocking the lens	54
Using the Custom Focus Range Limiter Function	56
Lens markings	57
Accessories	58
External flash layout	58
Connecting the external flash	59
Shooting modes	60
AUTO Auto mode	60
P Program mode	62
Program Shift	63
Minimum shutter speed	63
A Aperture Priority mode	64
S Shutter Priority mode	65
M Manual mode	66
Using the Bulb function	66
C Custom mode	67
Saving custom modes	67
Downloading custom modes	68

Selecting custom modes	68
Deleting custom modes	68
SAS Samsung Auto Shot mode	69
S Smart mode	71
Capturing panoramic photos	72
Recording a video	73
3D mode	75
Available functions by shooting mode	76

Chapter 2

Shooting Functions

Size and Resolution	78
Photo size	78
Quality	79
ISO sensitivity	80
Customizing ISO settings	81
OLED Color	82
White Balance	83
Customizing preset White Balance options	84
Picture Wizard (photo styles)	85
Smart Filter	86
AF mode	87
Single AF	88
Continuous AF	88
Active AF	89
Manual focus	89

AF area	90	Interval Capture	105
Selection AF	90	Flash	106
Saving Selection AF position.....	90	Reducing the red-eye effect.....	107
Zone AF.....	91	Adjusting the flash intensity	107
Multi AF.....	91	Flash settings.....	108
Face Detection	92	Setting external flash	108
Normal.....	92	Setting wireless sync for external flash.....	109
Smile Shot.....	93	Locking the flash intensity.....	110
Wink Shot.....	93	Metering	111
Touch AF	94	Multi.....	111
Touch AF.....	94	Center-weighted	112
AF Point.....	94	Spot.....	112
Tracking AF.....	94	Measuring the exposure value of the focus area	113
One Touch Shot.....	95	Dynamic Range	114
Focus assist	96	Exposure compensation	115
MF Assist.....	96	Using Framing Mode.....	115
DMF (Direct Manual Focus)	97	Using the brightness adjustment guide	116
Setting MF & DMF responsiveness.....	97	Viewing the overexposure guide.....	116
AF Release Priority	97	Exposure/Focus lock	117
Focus Peaking.....	98	Exposure/Focus separation	118
Optical Image Stabilization (OIS)	99	Video functions	119
Drive (shooting method)	100	Movie size.....	119
Single.....	100	When Video Out is set to NTSC.....	119
Continuous	101	When Video Out is set to PAL	120
Burst.....	101	Movie quality	120
Timer.....	102	Bit rates for movie sizes	121
Auto Exposure Bracketing (AE Bracket).....	102	Fast/Slow Movie.....	122
White Balance Bracketing (WB Bracket).....	103	AF Responsiveness	122
Picture Wizard Bracketing (P Wiz Bracket).....	103	AF Shift Speed	123
Depth Bracketing	104	Fader	123
Bracketing settings	104		

Voice.....	124
Wind Cut.....	124
Mic Level.....	124
Smart Range+.....	124

Chapter 3

Playback/Editing

Searching and managing files.....	126
Viewing photos.....	126
Viewing image thumbnails.....	126
Viewing files by category.....	127
Viewing continuous and burst shots.....	128
Protecting files.....	129
Lock/Unlock all files.....	129
Deleting files.....	130
Deleting a single file.....	130
Deleting multiple files.....	130
Deleting all files.....	130
Viewing photos.....	131
Enlarging a photo.....	131
Viewing a slide show.....	132
Viewing the overexposure guide.....	133
Viewing interval shots.....	133
Sorting files.....	133
Auto rotating.....	133
Converting to JPEG.....	133

Playing videos.....	134
Scanning backward or forward.....	134
Adjusting the brightness of a video.....	135
Adjusting the volume of a video.....	135
Trimming a video during playback.....	136
Capturing an image during playback.....	136
Editing photos.....	137
Cropping a photo.....	137
Rotating a photo.....	138
Resizing photos.....	138
Adjusting your photos.....	139
Retouching faces.....	139
Applying Smart Filter effects.....	140

Chapter 4

Connecting & Transferring

Connecting to a smart phone.....	142
Using the NFC Feature.....	142
Using NFC features in Shooting mode.....	142
Using NFC features in Playback mode (Photo Beam).....	143
Using the GPS Geo Tagging Feature.....	143
Sending files to a smart phone.....	144
Controlling the camera remotely with a smart phone.....	146
Using a smart phone as a remote shutter release.....	148
Saving files to a smart phone automatically.....	149
Downloading custom modes via a smart phone.....	151

Sending photos via email.....	153
Connecting to a WLAN.....	153
Setting network options.....	154
Manually setting the IP address.....	154
Network connection tips.....	155
Entering text.....	156
Sending photos via email.....	157
Storing a sender's information.....	158
Setting an email password.....	159
Changing the email password.....	160
Viewing photos or videos on a TV.....	161
Connecting wirelessly.....	161
Connecting via cable.....	163
Viewing files on a TV.....	163
Viewing files on a 3D TV.....	164
Connecting to a computer.....	165
Using Auto Backup for photos or videos.....	165
Installing the program for Auto Backup on your PC.....	165
Using the Auto Backup feature.....	165
Connecting the camera as a removable disk.....	167
Transferring files to your Windows OS computer.....	167
Disconnecting the camera (for Windows 7).....	168
Transferring files to your Mac OS.....	168

Chapter 5

Camera settings menu

User settings.....	171
Manage Custom Mode.....	171
RAW Compression.....	171
Noise Reduction.....	171
Color Space.....	172
Distortion Correct.....	173
User Display.....	173
Grid Line.....	173
Center Marker.....	174
Key Mapping.....	174
Custom.....	174
AEL.....	175
EV.....	176
Command Dial.....	177
iFn Setting.....	177
Lens Button Speed Settings.....	178
Touch Operation.....	178
Auto Self Shot.....	178
AF Lamp.....	178
E-Shutter.....	179
MobileLink/NFC Image Size.....	179
Setting.....	180

Chapter 6

Appendix

Error messages 186

Maintaining the camera..... 187

- Cleaning the camera 187
 - Camera lens and display 187
 - Image sensor 187
 - Camera body 187
- Using or storing the camera 188
 - Inappropriate places to use or store the camera 188
 - Using on beaches or shores 188
 - Storing for an extended period of time 188
 - Using the camera with caution in the humid environments 189
 - Other precautions 189
- About memory cards 190
 - Supported memory cards 190
 - Memory card capacity 191
 - Cautions when using memory cards 193
- About the battery 194
 - Battery specifications 194
 - Battery life 195
 - Low battery message 195
 - Notes about using the battery 195
 - Battery precautions 196
 - Notes about charging the battery 196
 - Notes about charging with a computer connected 197
 - Handle and dispose of batteries and chargers with care 197

Using programs on a PC..... 198

- Installing i-Launcher 198
- Using i-Launcher 200
 - Opening i-Launcher 200
 - Available programs 200
 - Requirements 201
- Installing Samsung RAW Converter 202
- Using Samsung RAW Converter 202

Updating the firmware..... 203

- Connecting via USB cable 203
- Connecting via Wi-Fi 204

Before contacting a service center 205

Camera specifications 208

Glossary 211

Optional accessories..... 217

Index 218

Concepts in Photography

Shooting postures

A correct posture for stabilizing the camera is necessary for taking a good photo. Even if you hold a camera correctly, the wrong posture can cause the camera to shake. Stand up straight and remain still to maintain a steady base for your camera. When shooting with a slow shutter speed, hold your breath to minimize body movement.

Holding the camera

Hold the camera with your right hand and place your right index finger on the shutter button. Place your left hand under the lens for support.

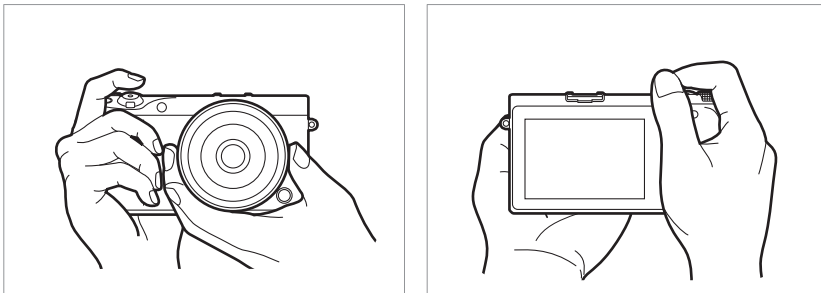

Standing photography

Compose your shot, stand up straight with your feet shoulder-length apart, and keep your elbows pointed down.

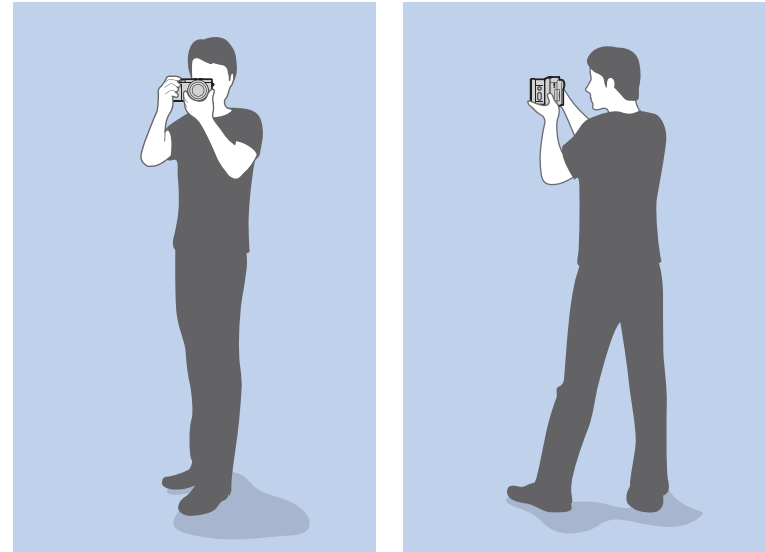

Crouching photography

Compose your shot, crouch with one knee touching the ground, and keep a straight posture.

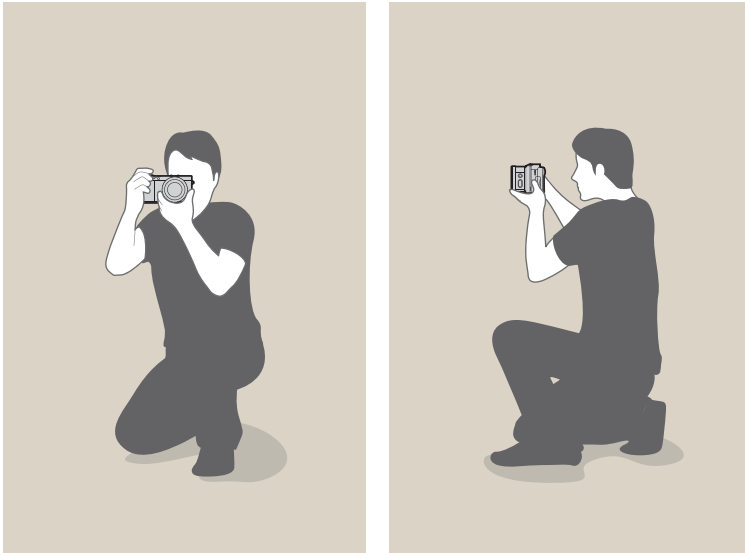

Using the display

To take photos at high or low angles, tilt the display up or down.

- 1 Slide the display downwards carefully.

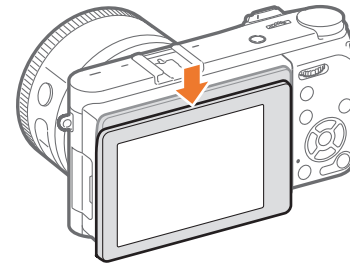

- 2 Tilt the display from 180° upwards to 45° downwards.

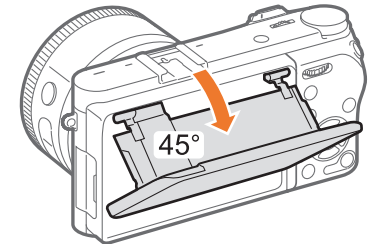
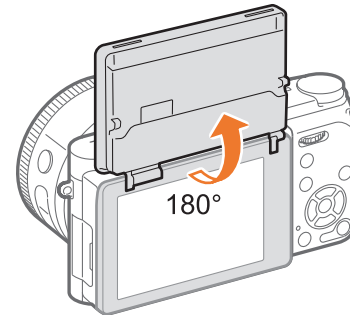

- To capture a self-portrait, set **Auto Self Shot** to **On**, flip the display 180° upwards and touch the subject on the display. (p. 33)

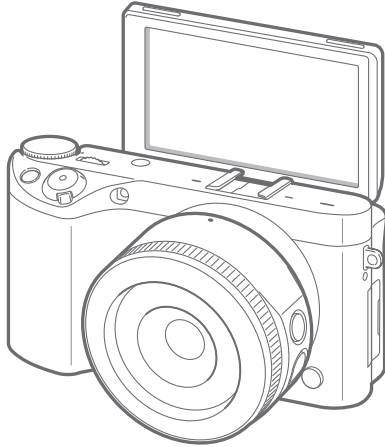

- Keep the display closed when the camera is not in use.
- Tilt the display only within the angle allowed. Failing to do so may damage your camera.
- Be careful not to damage the display when tilting it.
- If you have flipped the display upwards and you are not holding the camera by hand, do not rest the camera on a table, fence, etc. to steady it. Instead, use a tripod. Otherwise, you can damage your camera.
- Do not flip the display up when an external flash is mounted on the camera. Otherwise, you may damage your camera.

Low-angle shot

A low-angle shot is a shot from a camera positioned below your eyeline, looking up the subject.

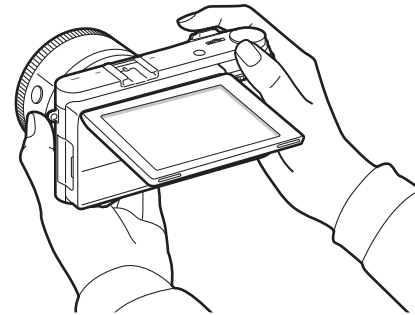

High-angle shot

A high-angle shot is a shot from a camera positioned above your eyeline, looking down on the subject.

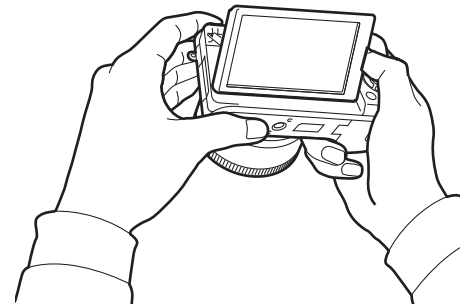

Aperture

The aperture is one of the three factors that determine the exposure. The aperture housing contains thin, metal plates that open and close to let light through the aperture and into the camera. The size of the aperture is related to the amount of light: a larger aperture allows more light and a smaller aperture allows less light.

Aperture sizes

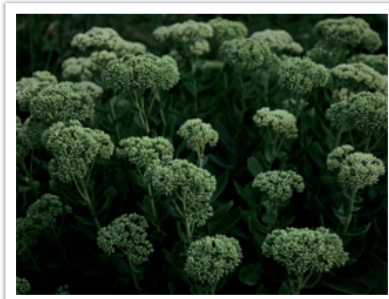
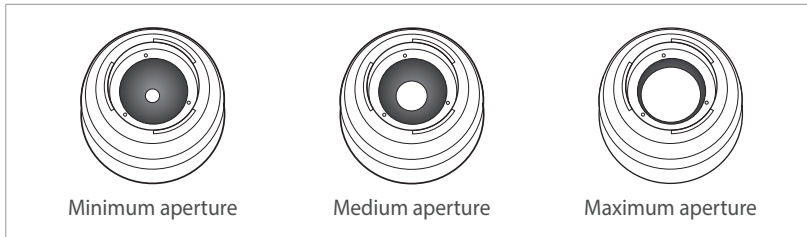

Aperture opened slightly



Aperture opened wide

The size of the aperture is indicated by a value known as the “F-number”. The f-number represents the focal length divided by the diameter of the lens. For example, if a lens with a 50 mm focal length has an f-number of F2, the diameter of the aperture is 25 mm. ($50 \text{ mm} / 25 \text{ mm} = F2$) The smaller the f-number, the greater the size of the aperture.

The relative size of the opening in the aperture is indicated by the Exposure Value (EV). Increasing the Exposure Value (+1 EV) means the amount of light doubles. Decreasing the Exposure Value (-1 EV) means the amount of light halves. You can also use the exposure compensation feature to fine-tune the amount of light by subdividing exposure values into 1/2, 1/3 EV, and so on.

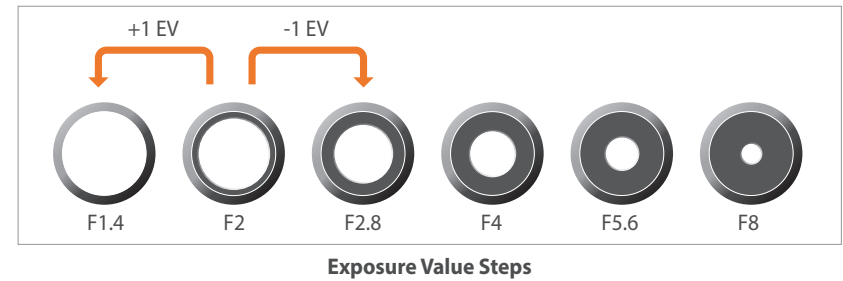

Aperture value and the depth of field

You can blur or sharpen the background of a photo by changing the size of the aperture. A large aperture gives your photos a shallow depth of field (DOF). Objects immediately in front of or behind your subject will be blurred, while the subject will be in focus. A small aperture gives your photos a deep depth of field. Objects far in front or far behind your subject and your subject will be in focus.



A photo with a deep DOF



A photo with a shallow DOF



The aperture housing contains several blades. These blades move together and control the amount of light passing through the center of the aperture. The number of blades also affects the shape of light when shooting night scenes. If an aperture has an even number of blades, light divides into an equal number of sections. If the number of blades is odd, the number of sections is double the number of blades.

For example, an aperture with 8 blades divides light into 8 sections and an aperture with 7 blades into 14 sections.

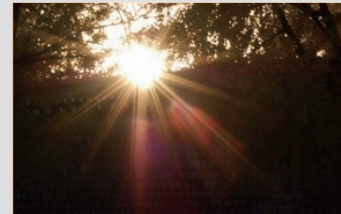

7 blades

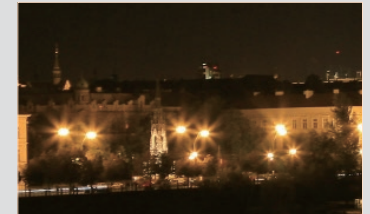

8 blades

Shutter speed

Shutter speed refers to the amount of time it takes to open and close the shutter. It controls the amount of light which passes through the aperture before it reaches the image sensor.

Shutter speeds are measured in seconds and parts of a second. On many cameras, the shutter speeds are approximately halved with each succeeding setting - 1 s, 1/2 s, 1/4 s, 1/8 s, 1/15 s, etc. Like successive aperture settings, each successive shutter speed setting lets in about half the amount of light. Consequently, each successive shutter speed setting equals an EV (Exposure Value) change of about 1 EV.

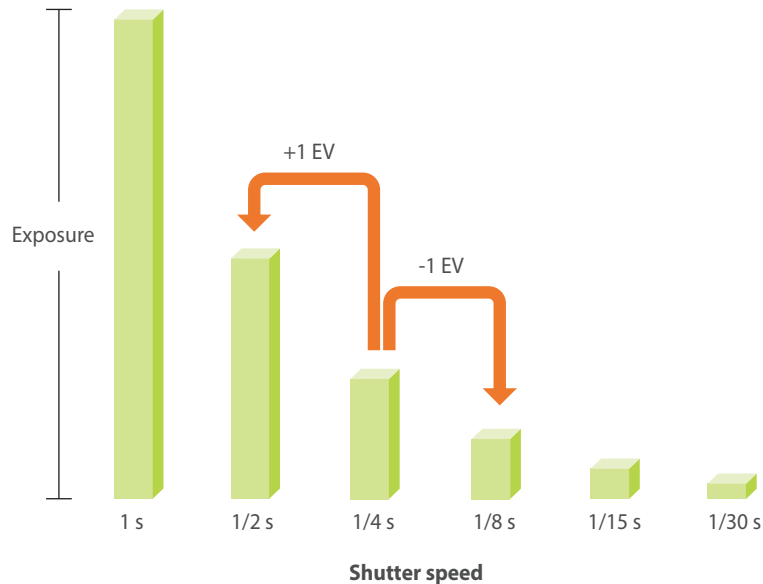

Therefore, the faster the shutter speed, the less light will be let in. Likewise, the slower the shutter speed, the more light will be let in.

A slow shutter speed allows more light into the camera, making photos brighter. However, because the shutter is open longer, moving subjects appear blurred. A fast shutter speed allows less light in, making photos darker. However, because the shutter is open for a shorter time, moving subjects look sharper and more focused.

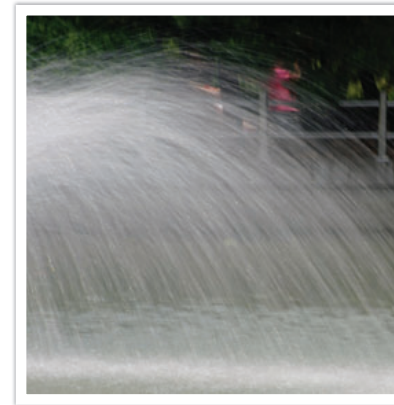

1 s

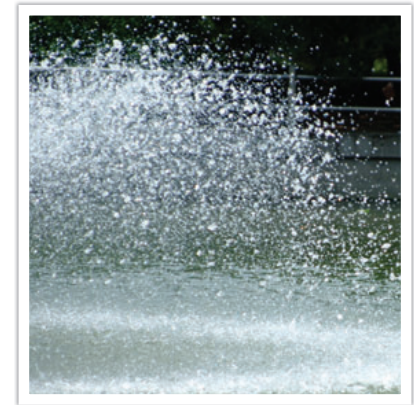

1/250 s

ISO sensitivity

The exposure of an image is determined by the sensitivity of the camera to light. This sensitivity is measured by a set of international film standards, known as ISO standards. On digital cameras, this sensitivity rating is used to indicate the light sensitivity of the digital sensor that captures the image.

ISO sensitivity doubles as the ISO number doubles. For example, an ISO 200 setting is capable of capturing images at twice the speed of an ISO 100 setting. However, higher ISO settings can result in “noise”—small specks, spots, and other phenomena in a photo that give the shot a noisy or dirty appearance. As a general rule, it is best to use a low ISO setting to prevent noise in your photos, unless you are shooting in darkened environments or at night.



A photo captured with a low ISO setting.
The photo is clear.

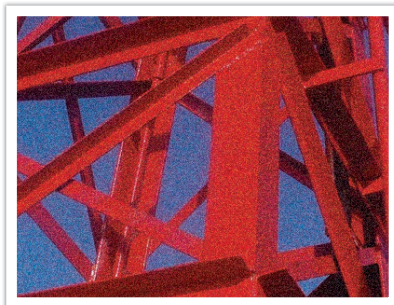

The same shot captured with a high ISO setting.
The photo is grainy.

Because a low ISO setting means the camera will be less sensitive to light, you need more light to have an optimal exposure. When using a low ISO setting, open the aperture more or reduce the shutter speed to allow more light to enter the camera. For example, on a sunny day when light is abundant, a low ISO setting does not require a slow shutter speed. However, in a dark place or at night, a low ISO setting will result in a blurry photo. To compensate for the lower light level, you should increase the ISO setting by a moderate amount.



A photo captured with a tripod and a high ISO setting.





A blurred photo captured by a camera.

How the aperture setting, shutter speed, and ISO sensitivity control exposure

The aperture setting, shutter speed, and ISO sensitivity are closely interconnected in photography. The aperture setting controls the opening that regulates the light that enters the camera, while the shutter speed determines the length of time that light is allowed to enter. ISO sensitivity determines the speed at which the film or digital image sensor reacts to light. Together, these three aspects are described as the triangle of exposure.

A change in shutter speed, aperture value, or ISO sensitivity can be offset by adjustments to the others to maintain the amount of light. The results, however, change according to the settings. For example, shutter speed is useful in expressing movement, aperture can control the depth of field, and ISO sensitivity can control the graininess of a photo.

	Settings	Results
Aperture value	Wide aperture = more light Narrow aperture = less light	 <p>Wide = shallow depth of field Narrow = deep depth of field</p>

	Settings	Results
Shutter speed	Fast speed = less light Slow speed = more light	 <p>Fast = still Slow = blurry</p>
ISO sensitivity	High sensitivity = more sensitive to light Low sensitivity = less sensitive to light	 <p>High = more grainy Low = less grainy</p>

Correlation between focal length, angle, and perspective

Focal length, which is measured in millimeters, is the distance between the middle of the lens to its focal point. It affects the angle and perspective of captured images. A short focal length translates into a wide angle, which allows you to capture a wide shot. A long focal length translates into a narrow angle, which allows you to capture telephoto shots.

Short focal length

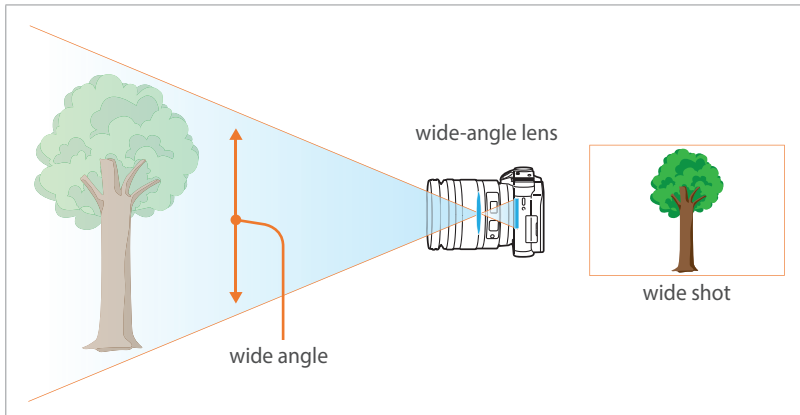

Long focal length

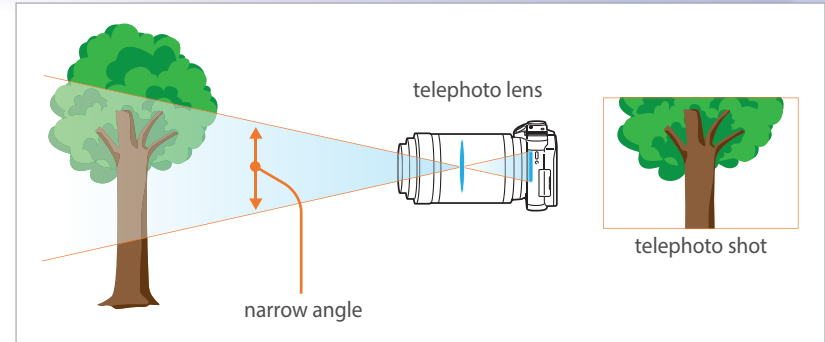

Look at these photos below and compare the changes.



16 mm angle



50 mm angle

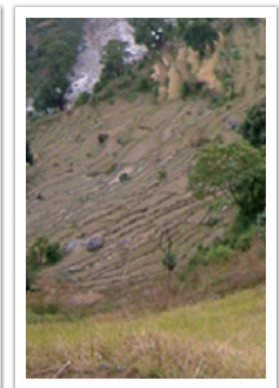

200 mm angle



Normally, a lens with a wide angle is suitable for shooting landscapes and a lens with a narrow angle is recommended for shooting sports events or portraits.

Depth of field

The depth of field (DOF) is the focused area around the subject.

In general, the DOF can be shallow or deep. In photos with a shallow DOF, the subject is sharply focused, the background is blurred and the subject stands out. In contrast, photos with a deep DOF have all the elements of the photo in sharp focus.

You can create a photo with a shallow DOF by using a telephoto lens or by selecting a low aperture value. You can create a photo with a deep DOF by using a wide angle lens or by selecting a high aperture value.



Shallow Depth of Field

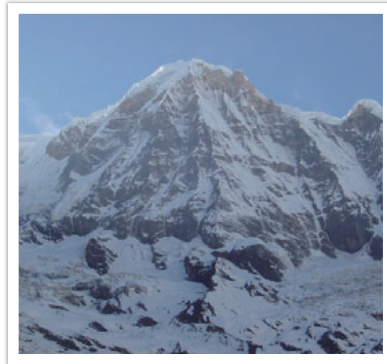

Deep Depth of Field

What controls out-of-focus effects?

DOF depends on the aperture value

A low aperture value indicates that the aperture has a wide opening. The wider the aperture, the shallower the DOF becomes. Conversely, a high aperture value indicates that the aperture has a narrow opening. The narrower the aperture, the deeper the DOF becomes.

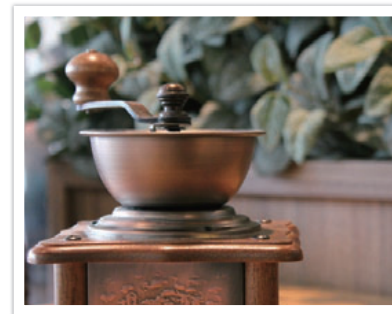

50 mm F5.7



50 mm F22

DOF depends on focal length

The longer the focal length, the shallower the DOF. A telescopic lens with a longer focal length will capture a photo with a shallow DOF better than a lens with a shorter focal length.



A photo captured with an 16 mm wide-angle lens

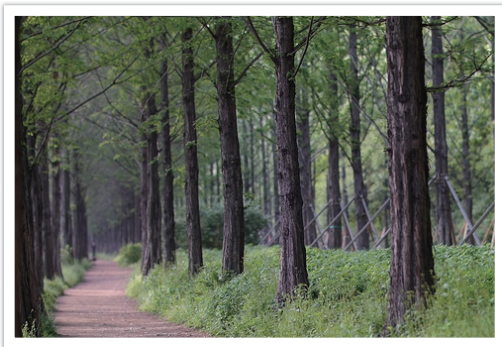

A photo captured with a 100 mm telescope lens

DOF depends on the distance between the subject and the camera

The shorter the distance between the subject and the camera, the shallower the DOF is. Therefore, taking a photo close to a subject generally results in a photo with a shallow DOF.



A photo captured with a 100 mm telescope lens

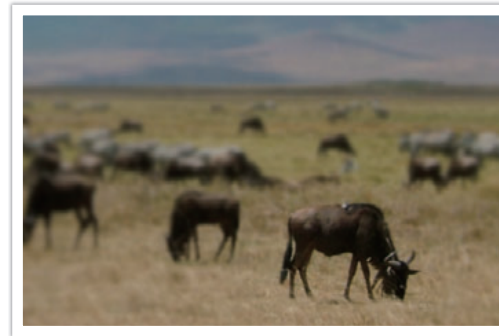

A photo captured close to the subject

DOF preview

You can press the Custom button to get an idea of what your shot will look like before shooting. The camera adjusts the aperture to the predefined settings and shows the results on the screen. Set the function of the Custom button to **Optical Preview**. (p. 174)

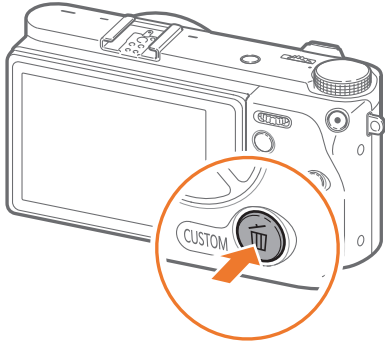

Composition

The way that objects are arranged in a photo is referred to as its composition. A good composition emphasizes the photo's subjects by drawing attention to them and by balancing them with the other elements in the photo.

Following the rule of thirds is one method that usually results in good compositions.

Rule of Thirds

To use the rule of thirds, divide the image into a 3x3 pattern of equal rectangles.

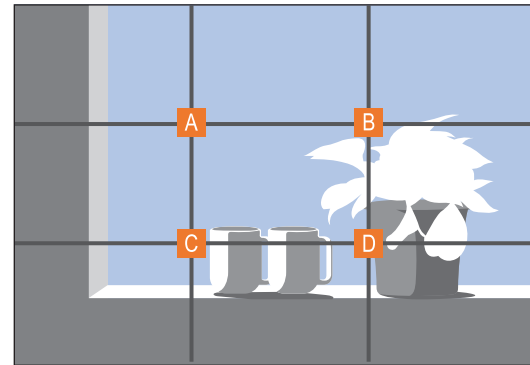

To compose photos that best emphasize the subject, make sure the subject is located at one of the corners of the center rectangle.

Using the rule of thirds will create photos with stable and compelling compositions. Below are a few examples.

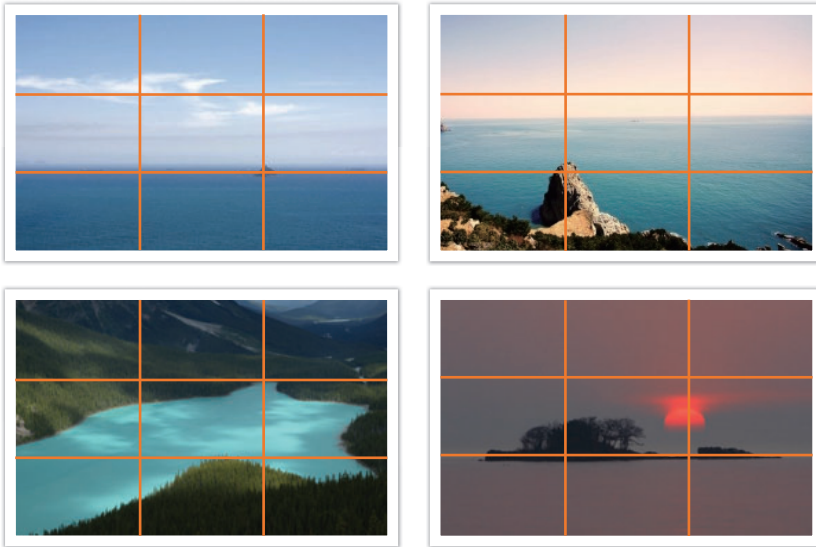

Photos with two subjects

If your subject is in one corner of the photo, it creates an unbalanced composition. You can stabilize the photo by capturing a second subject in the opposite corner to balance the weight of the photo.

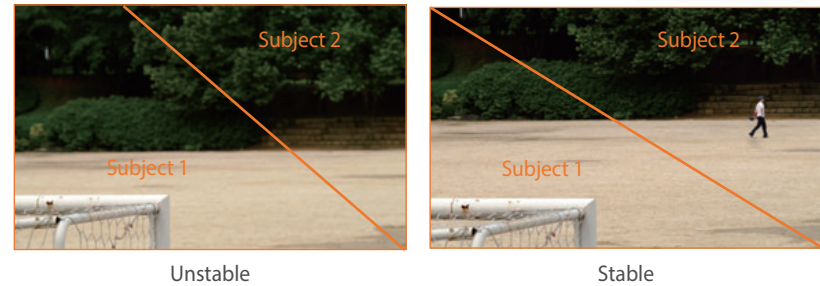

When taking landscape photos, centering the horizon will create an unbalanced effect. Give more weight to the photo by moving the horizon up or down.



Flash

Light is one of the most important components in photography. However, you will not always have enough of light in all situations. Making use of a flash allows you to compensate for the lack of light and create a variety of effects.

The flash, also known as a strobe or speed light, provides adequate exposure in low-light conditions. It is also useful in light-abundant situations. For example, you can use the flash to provide light when a subject is in shadow or use it to capture clearly both the subject and the background under backlit conditions.



Back lit subjects without flash



Back lit subjects with flash

Flash guide number

The model number of a flash refers to the flash's power, and the maximum amount of light created is indicated by a value known as the "guide number". A flash with a higher guide number emits a larger amount of light than a flash with a lower guide number. The guide number is calculated by multiplying the distance from the flash to the subject by the aperture value when the ISO sensitivity is set to 100.

Guide number = Flash to Subject Distance X Aperture value

Aperture value = Guide number/Flash to Subject Distance

Flash to Subject Distance = Guide number/Aperture value

If you know the flash's guide number, you can estimate an appropriate flash-to-subject distance when setting the flash manually. For example, if a flash has a guide number of GN 20 and is 4 meters away from the subject, the optimal aperture value is F5.0.

Bounce Photography

Bounce photography refers to the method of bouncing light off of the ceiling or walls so that the light spreads evenly over the subject. Normally, photos captured with the flash may appear unnatural and cast shadows. Subjects in photos captured with bounce photography cast no shadows and look smooth due to evenly spread light.





Chapter 1

My Camera

Learn about your camera's layout, display icons, lens, optional accessories, and basic functions.

Getting started

Unpacking

Check your product box for the following items.

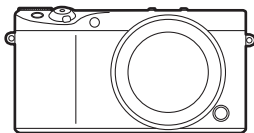

Camera
(including the body cap)

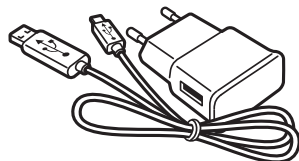

AC adapter/USB cable

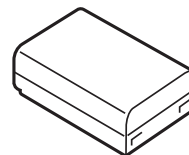

Rechargeable battery



Strap



External flash

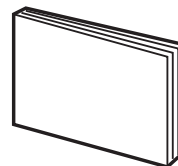

Quick Start Guide



- The illustrations may differ from your actual items.
- You can purchase optional accessories at a retailer or a Samsung service center. Samsung is not responsible for any problems caused by using unauthorized accessories. For information about accessories, refer to page 217.

Camera layout

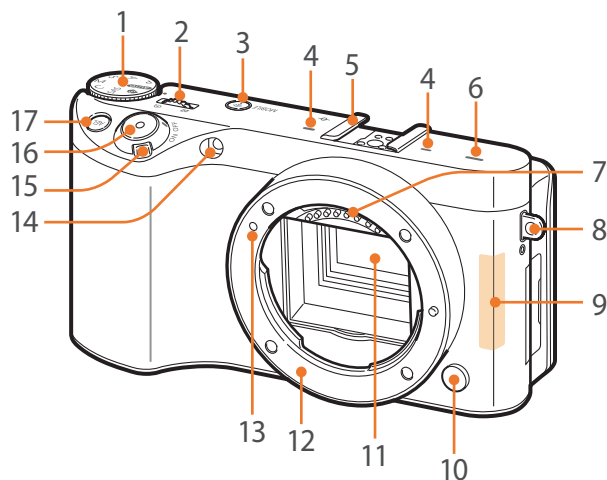

No.	Name
1	Mode dial <ul style="list-style-type: none"> • AUTO: Auto mode (p. 60) • P: Program mode (p. 62) • A: Aperture Priority mode (p. 64) • S: Shutter Priority mode (p. 65) • M: Manual mode (p. 66) • C: Custom mode (p. 67) • SAS: Samsung Auto Shot mode (p. 69) • S: Smart mode (p. 71)

No.	Name
2	Command dial 1 <ul style="list-style-type: none"> • In the Menu screen: Move to a desired menu item. • In the Smart panel: Adjust a selected option. • In Shooting mode: Adjust shutter speed, aperture value, Program Shift settings, exposure value, or ISO sensitivity in some shooting modes or change the size of a focus area. (p. 177) • In Playback mode: View thumbnails or enlarge or reduce a photo. Open or close a photo bundle in Playback mode. Scan backward or forward through a video.
3	MOBILE button Select a Wi-Fi function.
4	Microphone
5	Hot-shoe
6	Speaker
7	Lens contacts * Avoid contact with or prevent damage to the lens contacts.

No.	Name
8	Eyelet for camera strap
9	Internal antenna * Avoid contact with the internal antenna while using a wireless network.
10	Lens release button
11	Image sensor * Avoid contact with or prevent damage to the image sensor.
12	Lens mount
13	Lens mount index
14	AF-assist light/Timer lamp
15	Power switch
16	Shutter button
17	AEL button (p. 117) <ul style="list-style-type: none"> • In Shooting mode: Lock the adjusted exposure value or focus or perform the assigned function. • In Playback mode: Protect the selected file.

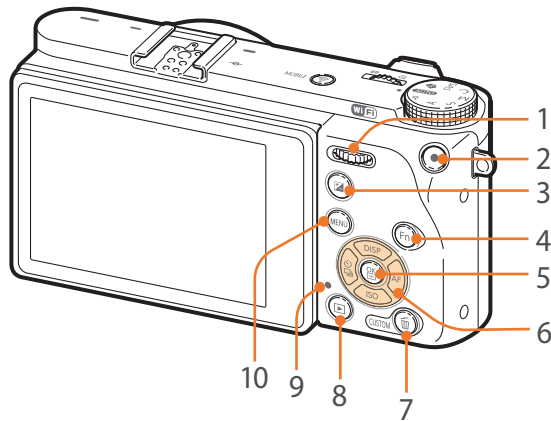

No.	Name
1	<p>Command dial 2</p> <ul style="list-style-type: none"> • In the Menu screen: Move to a desired menu item. • In the Smart panel: Move to a desired option. • In Shooting mode: Adjust shutter speed, aperture value, Program Shift settings, exposure value, or ISO sensitivity in some shooting modes or move the focus area. (p. 177) • In Playback mode: View the previous or next file. Scan backward or forward through a video.

No.	Name
2	<p>Video recording button</p>
3	<p>EV button</p> <ul style="list-style-type: none"> • Press and hold the button, and then scroll command dial 1 to adjust the exposure value. (p. 115) • Perform the assigned function. (p. 176)
4	<p>Fn button</p> <ul style="list-style-type: none"> • When capturing a photo: Access the Smart panel to fine-tune settings. • When recording a video: Switch between AF and MF.
5	<p>OK button</p> <ul style="list-style-type: none"> • In the Menu screen: Save the selected options. • In Shooting mode: Allows you to select a focus area manually in some shooting modes.
6	<p>Navigation button</p> <ul style="list-style-type: none"> • In Shooting mode <ul style="list-style-type: none"> - DISP: Change the information on the display. - ISO: Select an ISO value. - : Select a shooting method or set the timer. - AF: Select an AF mode. • In other situations Move up, down, left, right, respectively.

No.	Name
7	<p>Delete/Custom button</p> <ul style="list-style-type: none"> • In Shooting mode: Switch to Video recording standby mode or perform the assigned function. (p. 174) • In Playback mode: Delete files.
8	<p>Playback button</p> <p>Enter Playback mode to view pictures or videos.</p>
9	<p>Status lamp</p> <p>Indicates the status of the camera.</p> <ul style="list-style-type: none"> • Blinking: When saving a photo, shooting a video, sending data to a computer, connecting to WLAN, or sending a photo. • Steady: When there is no data transfer, when data transfer to a computer is complete, or charging the battery.
10	<p>MENU button</p> <p>Access options or menus.</p>

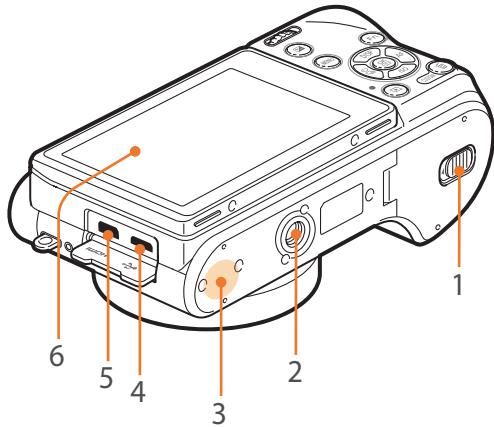

No.	Name
1	Battery chamber/Memory card cover
2	Tripod mount
3	NFC tag
4	USB and shutter release port Connect the camera to a computer or shutter release. Use a shutter release cable with a tripod to minimize camera movement.
5	HDMI port
6	Touch screen <ul style="list-style-type: none">• To take photos at high or low angles, tilt the display up or down. (p. 14, 33)• Touch the screen to select a menu or an option. (p. 40)

Using the display

You can take a self-portrait while looking at yourself in the display by flipping the display up.

Using the Self Shot mode

When you enable the Auto Self Shot option (p. 178), flipping the display upward activates Auto Self Shot mode.

In Self Shot mode, the timer (2 seconds), one-touch shot, face detection, and beauty face functions are automatically activated.

1 In Shooting mode, press [MENU] →  → **Auto Self Shot** → **On**.

2 Flip the display upward.

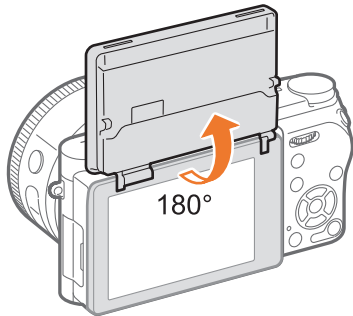

3 Touch .



4 Drag the slider or touch the +/- icons to adjust **Face Retouch**.

5 Press [] or touch **Set**.

6 Touch the frame area on the display or press [**Shutter**].

- After 2 seconds, the camera automatically releases the shutter.



- If you flip the display to capture a self-portrait, the captured image will be flipped horizontally. Press [MENU] →  → **Save as Flipped** → **On** to activate or deactivate the function.
- To deactivate Self Shot mode, touch . The camera can switch Self Shot mode to the previous mode (flipping down).
- The camera will automatically set the ISO sensitivity.
- You cannot adjust the desired shutter speed and aperture value.



- Keep the display closed when the camera is not in use.
- Tilt the display only within the angle allowed. Failing to do so may damage your camera.
- Be careful not to damage the display when tilting it.
- If you have flipped the display upwards and you are not holding the camera by hand, do not rest the camera on a table, fence, etc. to steady it. Instead, use a tripod. Otherwise, you can damage your camera.
- Do not flip the display up when an external flash is mounted on the camera. Otherwise, you may damage your camera.

Inserting the battery and memory card

Learn how to insert the battery and an optional memory card into the camera.

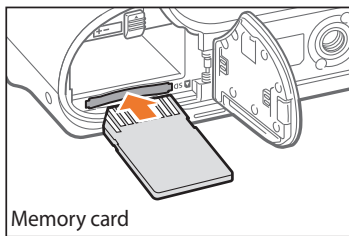
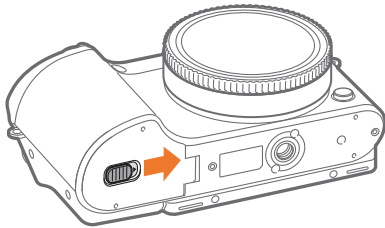

Memory card

Insert the memory card with the gold-colored contacts facing up.

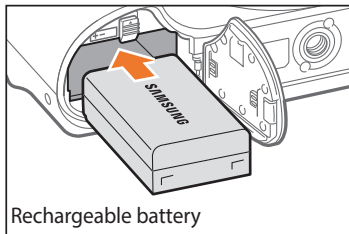

Rechargeable battery

Insert the battery with the Samsung logo facing up.

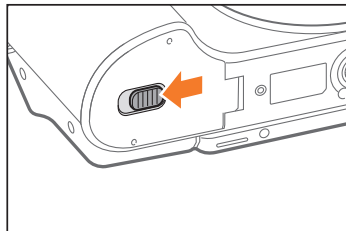
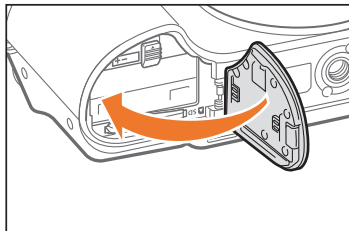

Removing the battery and memory card

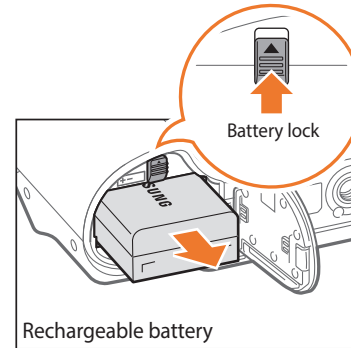

Rechargeable battery

Slide the lock up to release the battery.

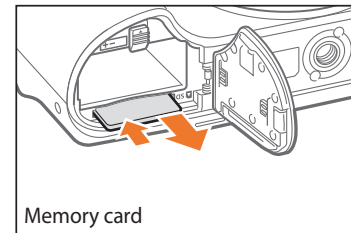

Memory card

Push the card gently until it disengages from the camera, and then pull it out of the slot.

Using the memory card adapter

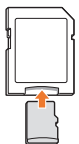

To use micro memory cards with this camera, a PC, or a memory card reader, insert the card into an adapter.



While the status lamp of the camera is blinking, do not remove the memory card or battery. Doing so may damage the data stored on the memory card or your camera.



Charging the battery and turning on your camera

Charging the battery

Before you use the camera for the first time, you must charge the battery. Plug the small end of the USB cable into your camera, and then plug the other end of the USB cable into the AC adapter.

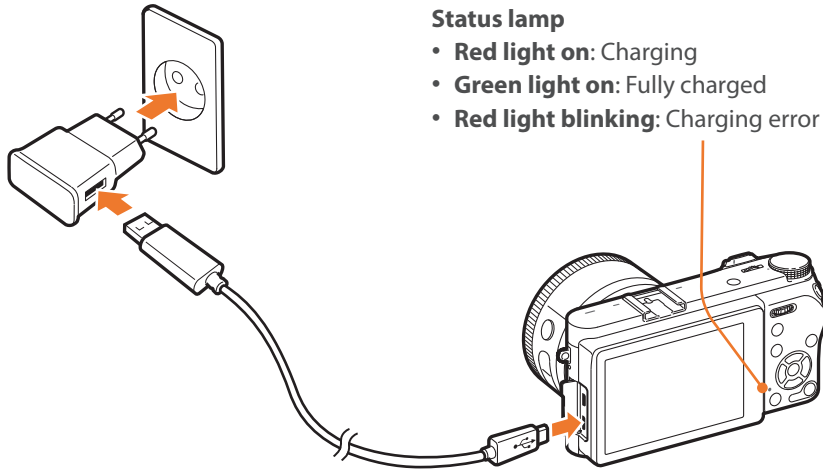

Status lamp

- **Red light on:** Charging
- **Green light on:** Fully charged
- **Red light blinking:** Charging error



- Charge the battery while the camera is turned off.
- Use only the AC adapter and USB cable supplied with your camera. If you use another AC adapter, the camera battery may not charge or work properly.

Turning on your camera

Set the Power switch to **ON**.

- To turn your camera off, set the Power switch to **OFF**.
- The initial setup screen appears when you turn on the camera for the first time. (p. 37)

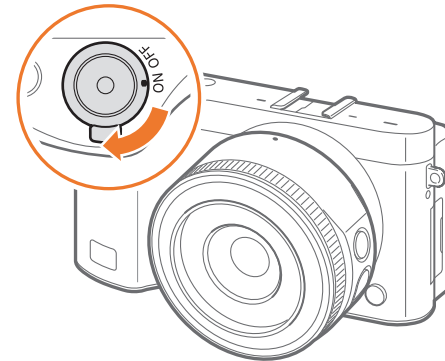

Performing the initial setup

When you turn on your camera for the first time, the initial setup screen appears. The language is preset for the country or region where the camera is sold. You can change the language as desired. You can also select an item by touching it on the screen.

- 1 Press [ISO] to select **Time Zone**, and then press [OK].
- 2 Press [DISP/ISO] to select a time zone, and then press [OK].

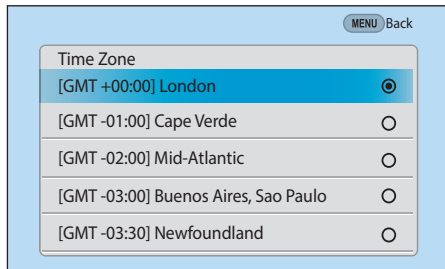

- 3 Press [ISO] to select **Date Settings**, and then press [OK].

- 4 Press [DISP/AF] to select an item (Year/Month/Day).
- 5 Press [DISP/ISO] to set the option, and then press [OK].

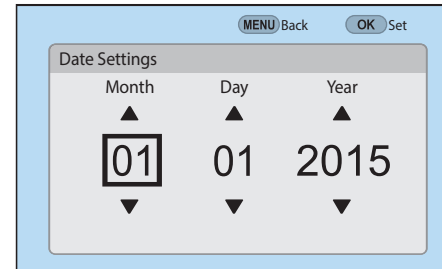

- The screen may differ depending on the language you selected.

- 6 Press [ISO] to select **Time Settings**, and then press [OK].
- 7 Press [DISP/AF] to select an item (Hour/Minute/Summer time).

8 Press [DISP/ISO] to set the option, and then press [OK].

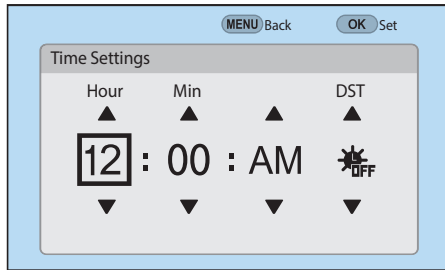

9 Press [ISO] to select **Date Type**, and then press [OK].

10 Press [DISP/ISO] to select a date type, and then press [OK].

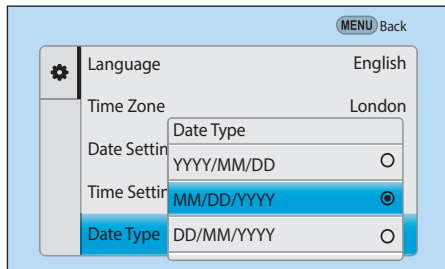

11 Press [ISO] to select **Time Type**, and then press [OK].

12 Press [DISP/ISO] to select a time type, and then press [OK].

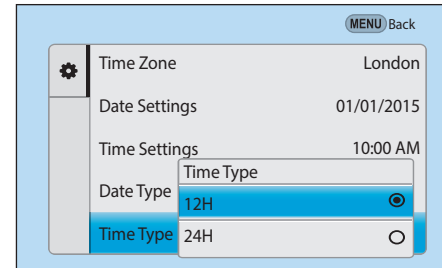

13 Press [MENU] to finish the initial setup.

Selecting functions (options)

Using buttons and dials

Use one of the following methods to select an option:

- Scroll command dial 1, and then press [OK].
- Scroll command dial 2, and then press [OK].
- Press [DISP/ISO/AF], and then press [OK].

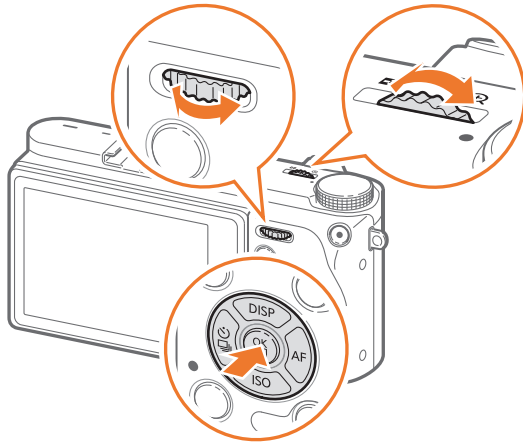

Using custom buttons and dials

Assign various buttons and dials to launch your favorite functions. Functions can be assigned to the following buttons and dials: Custom button, AEL button, EV button, and command dials 1 and 2.

- 1 In Shooting mode, press [MENU] → → **Key Mapping**.
- 2 Select a button from the list.
 - You can change the assigned functions of each button to a desired function.
- 3 Select a function.
- 4 Press [MENU] to move to the previous screen.
- 5 Set shooting options by using the custom buttons, and then capture a photo.

Selecting by touch



Do not use sharp objects, such as pens or pencils, to touch the screen. You can damage the screen.

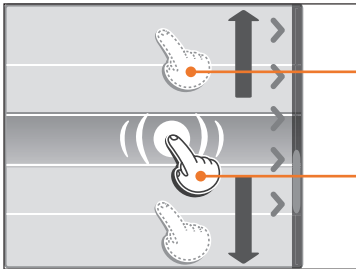

Dragging: Touch and hold an area on the screen, and then drag your finger.

Touching: Touch an icon to select a menu or an option.

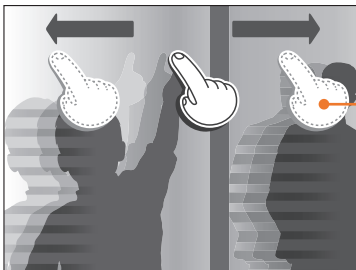

Flicking: Gently flick your finger across the screen.



- When you touch or drag the screen, discolorations may occur. This is not a malfunction, but a characteristic of the touch screen. Touch or drag lightly to minimize the discolorations.
- The touch screen may not work properly if you use the camera in extremely humid environments.
- The touch screen may not work properly if you apply screen protection film or other accessories to the screen.
- Depending on the viewing angle, the screen may appear dim. Adjust the brightness or viewing angle to improve the resolution.

Using MENU

Press [MENU] or touch **MENU** on the screen, and then change shooting options or settings.

E.g. Selecting the photo size in P mode

- 1 Rotate the mode dial to P.
- 2 Press [MENU] or touch **MENU**.

3 Scroll command dial 1 or press [DISP/ISO] to move to , and then press [].

- You can also touch  on the screen.

4 Scroll command dial 2 or press [DISP/ISO] to move to **Photo Size**, and then press [].

- You can also drag the option list, and then touch an option.

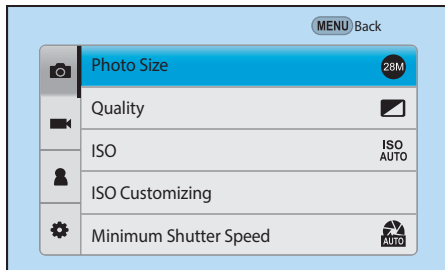

5 Scroll command dial 2 or press [DISP/ISO] to move to an option, and then press [].

- You can also drag the option list, and then touch an option.
- Press [MENU] or touch **Back** to go back to the previous menu.

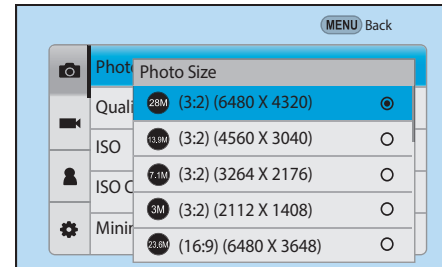

6 Press [MENU] or touch **Back** to switch to Shooting mode.



You can press [MENU] or touch **MENU** on the screen to change shooting options even in Video recording standby mode.

Using the smart panel

Press [Fn] or touch **Fn** on the screen to access some functions such as Exposure, ISO, and White Balance.

E.g. Adjust the exposure value in P mode

1 Rotate the mode dial to P.

2 Press [Fn] or touch **Fn**.

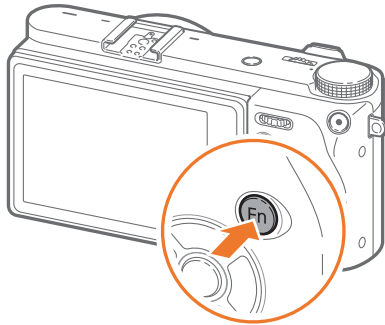

3 Scroll command dial 2 or press [DISP/ISO/AF] to move to **EV**, and then press [OK].

- You can directly select an option by scrolling command dial 1 without having to press [OK].

- You can also select an option by touching it.

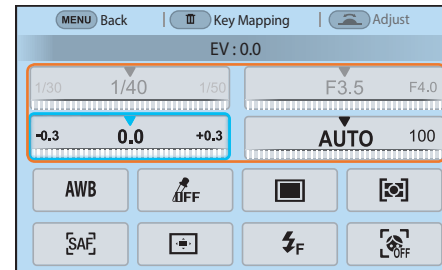

You can adjust some options by dragging them.

4 Scroll command dial 1 or command dial 2 or press [AF] to adjust the exposure value, and then press [OK].

- You can also drag the dial on the screen, and then touch **Set** to adjust the option.

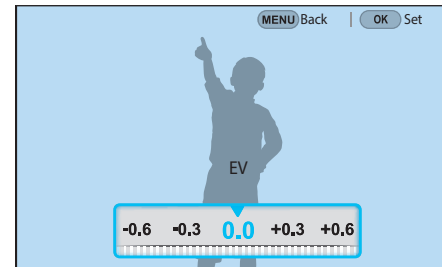

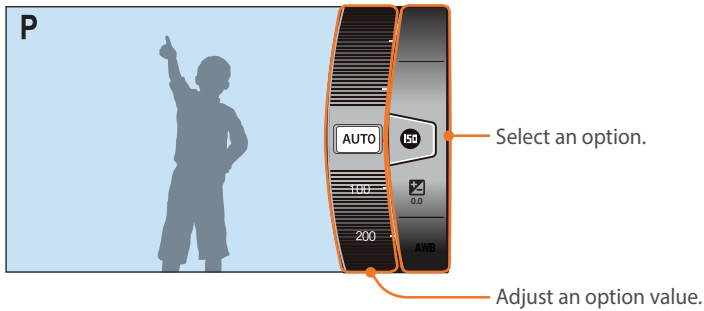

Using iFn

Press [**i-Function**] on an i-Function lens to manually select and adjust shutter speed, aperture value, exposure value, ISO sensitivity, and White Balance on the lens.



Using the iFn standard function

When you use [**i-Function**] on an i-Function lens, you can manually select and adjust shutter speed, aperture value, exposure value, ISO sensitivity, and White Balance on the lens. You can also use the Intelli-Zoom function.

- 1 Rotate the mode dial to P, A, S, or M.
- 2 Press [MENU] →  → **iFn Setting** → **iFn Standard**.
- 3 Press [MENU] to return to Shooting mode.
- 4 Press [**i-Function**] on the lens to select a setting.
 - To select items to appear, press [MENU] →  → **iFn Setting** → touch **iFn Standard** → select an item.

- You can also press [**i-Function**], and then press [DISP/ISO] or drag the screen to select a setting.

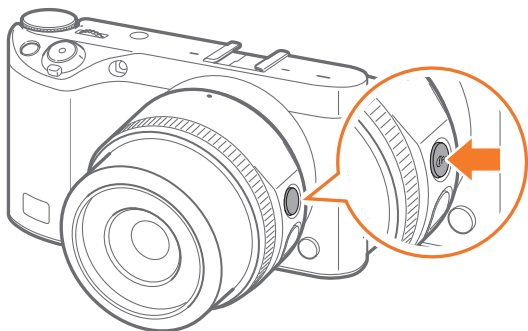

Option	Description
Aperture	Adjust the aperture value.
Shutter Speed	Adjust the shutter speed.
EV	Adjust the exposure value.
ISO	Adjust the ISO sensitivity.
White Balance	Select a White Balance option.
intelli-Zoom	Zoom in on a subject with less degradation of photo quality than the Digital zoom. However, the photo resolution or size may change compared to when you zoom in by rotating the zoom ring.

5 Adjust the focus ring to select an option.

- You can also scroll command dial 2 or drag the screen to select an option.

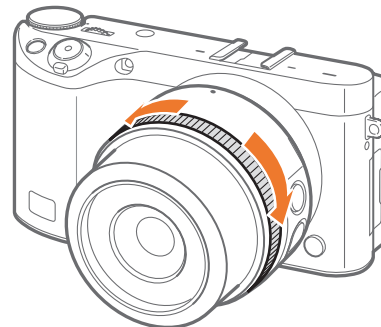

6 Half-press [**Shutter**] to focus, and then press [**Shutter**] to capture the photo.

Available options

Shooting mode	P	A	S	M	3D
Aperture	-	O	-	O	-
Shutter Speed	-	-	O	O	-
EV	O	O	O	-	O
ISO	O	O	O	O	-
White Balance	O	O	O	O	O
intelli-Zoom	O	O	O	O	-



- This function is not available when you attach a 3D lens and set **3D Auto mode** in 3D mode.
- intelli-Zoom is not available when you capture photos in the RAW file format.
- intelli-Zoom is deactivated when you capture photos continuously.
- intelli-Zoom is deactivated when you record videos by pressing the video recording button.

Using the iFn plus function

On an i-Function lens, press [**i-Function**], and then press [**AEL**] or [**FZ**] on the camera. You can assign functions to selected buttons or open the i-Functions settings menu.

E.g. Assigning the photo quality function to the AEL button

- 1 Rotate the mode dial to P, A, S, or M.
- 2 Press [MENU] →  → **iFn Setting**.
- 3 Touch **iFn Plus**, and then select **AEL** → **Quality**.
- 4 Press [MENU] to return to Shooting mode.
- 5 Press [**i-Function**] on an i-Function lens, and then press [**AEL**] on the camera.
- 6 Select a photo quality option.
- 7 Half-press [**Shutter**] to focus, and then press [**Shutter**] to capture the photo.

Display icons

In Shooting mode

Capturing photos

1. Shooting information

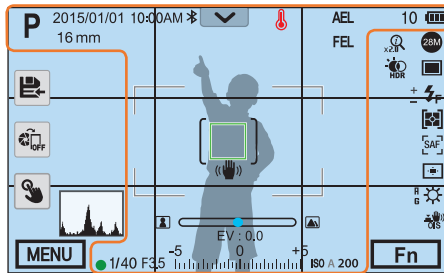

Icon	Description
P	Shooting mode
2015/01/01	Current date
10:00AM	Current time
	Bluetooth on
16 mm	Focal length*
	Notification panel bar (Touch)
	Overheating warning indicator
	Memory card not inserted**
AEL	Auto exposure lock (p. 117)
AFL	Auto focus lock (p. 117)
FEL	Flash intensity lock (p. 110)
10	Available number of photos
	Auto focus frame
[]	Spot metering area
	<ul style="list-style-type: none"> : Fully charged : Partially charged : Empty (recharge the battery) : Charging

Icon	Description
	Camera shake
	Manual focus scale
	Level gauge (p. 49)
	Histogram (p. 116)
	Focus
1/40	Shutter speed
F3.5	Aperture value
EV : 0.0	Exposure adjustment value
	Exposure level display
ISO A 200	ISO sensitivity (p. 80)

* This icon appears when you attach the Power Zoom lens.

** Photos that were captured without inserting a memory card cannot be transferred to a memory card or a computer.

2. Shooting options

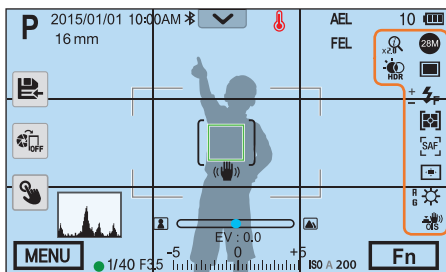

Icon	Description
	Photo size
	RAW file
	Drive mode
	Flash (p. 106)
	Flash intensity adjustment
	Metering (p. 111)
	AF mode (p. 87)
	Focus area

Icon	Description
	Face detection
	White Balance (p. 83)
	White Balance micro adjustment
	Optical Image Stabilization (OIS) (p. 99)
	intelli-zoom on
	intelli-zoom ratio
	Dynamic Range (p. 114)

3. Shooting options (Touch)

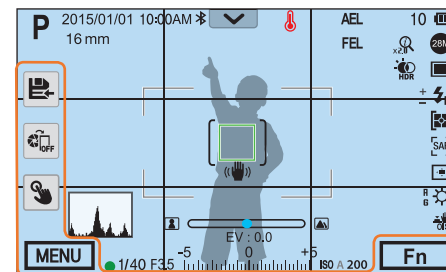

Icon	Description
	Change Smart mode*
	Save a custom mode
	Quick Transfer (p. 149)
	Touch AF options
	Shooting options
	Smart panel

* This icon appears only when you select Smart mode.



The icons displayed will change according to the mode you select or the options you set.

Recording videos

1. Shooting information

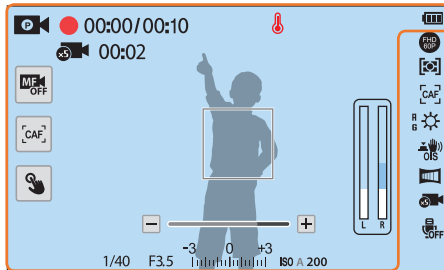

Icon	Description
	Shooting mode
	Switch between AF and MF. (Touch)
	Switch between Single AF and Continuous AF. (Touch)
	Touch AF option (Touch)
00:00/ 00:10	Current recording time/ Available recording time
	Fast/Slow Movie (p. 122)
00:02	Playback time after applying the Fast/Slow Movie feature
	Overheating warning indicator

Icon	Description
	<ul style="list-style-type: none"> : Fully charged : Partially charged (Red): Empty (recharge the battery) : Charging
	Zoom indicator*
	Exposure value
ISO A 200	ISO sensitivity (p. 80)
	Video sound level

* This icon appears when you attach the Power Zoom lens.

2. Shooting options

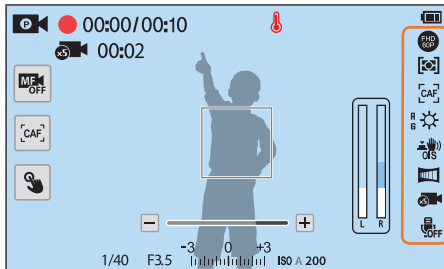

Icon	Description
	Video size
	Metering (p. 111)
	AF mode (p. 87)
	White Balance (p. 83)
	White Balance micro adjustment
	Optical Image Stabilization (OIS) (p. 99)

Icon	Description
	Fader (p. 123)
	Fast/Slow Movie (p. 122)
	Voice recording off (p. 124)
	Zoom button*

* This icon appears when you attach the Power Zoom lens.



The icons displayed will change according to the mode you select or the options you set.

About the level gauge

The level gauge helps you align the camera with the horizontal and vertical lines on the display. If the level gauge is not level, calibrate the level gauge using the Horizontal Calibration function. (p. 180)

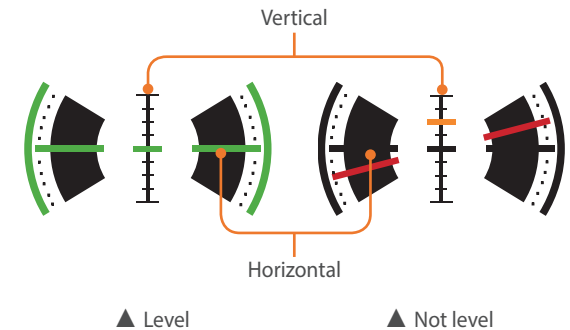

In Playback mode

Viewing photos



Information

Icon	Description
	View image thumbnails. (Touch)
1/10	Current file/The total number of files
	Notification panel bar (Touch)
	Send photos via email. (Touch)
	Share files with other devices. (Touch)
MENU	Playback/Editing/Setting menu (Touch)
	RAW file
	3D file
	Protected file

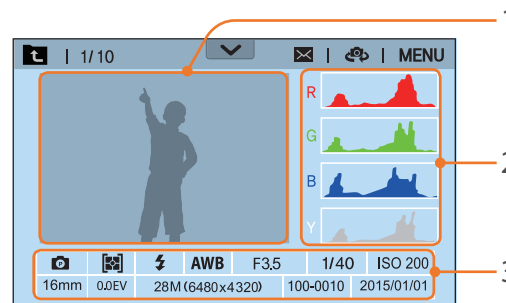

No.	Description
1	Captured photo
2	RGB histogram (p. 116)
3	Shooting mode, Metering, Flash, White Balance, Aperture value, Shutter speed, ISO, Focal length, Exposure value, Photo size, Folder number-File number, Date

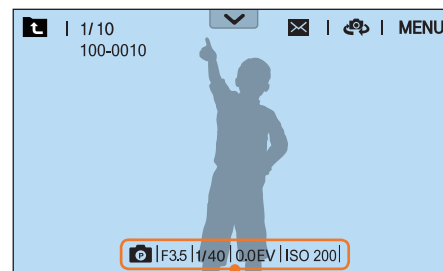

Basic Exif information

Playing videos

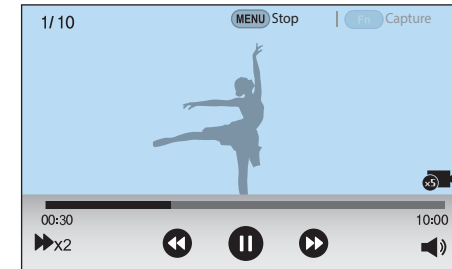

Icon	Description
	Playback speed
00:30	Current playback time
10:00	Video length
	Fast/Slow Movie
	View previous file/Scan backward. (Each time you touch the scan backward icon, you change the scan speed in this order: 2X, 4X, 8X.)
	Pause or resume playback.
	View next file/Scan forward. (Each time you touch the scan forward icon, you change the scan speed in this order: 2X, 4X, 8X.)
	Adjust the volume or mute the sound.

Changing the information displayed

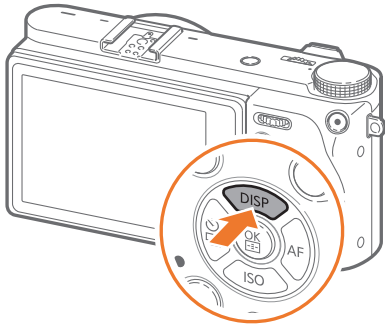

Press [DISP] repeatedly to change the display type.

Mode	Display type
Shooting	• Basic shooting information + Shooting option buttons + Current shooting options information
	• Basic shooting information (Shooting mode, Shutter speed, Aperture value, Exposure value, ISO sensitivity, etc.)
	• Basic shooting information + Shooting option buttons (MENU, Fn, Quick Transfer, Touch AF, Custom mode save) + Current shooting options information (Photo size, Drive mode, Flash, Metering, AF mode, etc.) + Histogram
	• Basic shooting information + Shooting option buttons + Current shooting options information + Level gauge
	• No information (when connected to an HDMI-supported TV or monitor)
Playback	• Basic information
	• Display all information about the current file.
	• Display all information about the current file including RGB histogram.

Viewing the notification panel

Touch  at the top of the display to open the notification panel. You can adjust the display brightness or view the current date and time, battery life, and data storage information. You can also view the status of a Bluetooth or Wi-Fi connection and enable or disable it. If a new version of the camera's firmware is available, when the camera is connected to a Wi-Fi network, the notification panel bar blinks and a notification appears at the upper right corner of the notification panel. Touch the bottom of the notification panel or press [MENU] or [Fn] to close it.

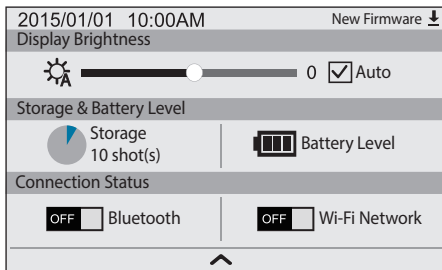

Lenses

You can purchase optional lenses made exclusively for your NX series camera.

Learn about the functions of each lens and select one that suits your needs and preferences.

Lens layout

SAMSUNG 16-50mm F3.5-5.6 Power Zoom ED OIS lens (example)

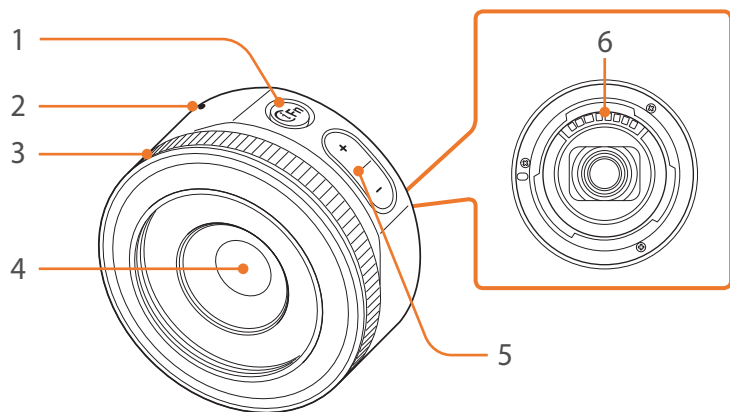

No.	Description
1	i-Function button (p. 43)
2	Lens mount index
3	Focus ring (p. 96) <ul style="list-style-type: none"> • Rotate the focus ring to adjust the zoom setting when using the auto focus function.
4	Lens
5	Zoom button <ul style="list-style-type: none"> • Press the zoom button to adjust the zoom ratio.
6	Lens contacts*

* Avoid contact with or prevent damage to the lens contacts.



When not using the lens, attach the lens cap and lens mount cover to protect the lens from dust and scratches.

SAMSUNG 20-50mm F3.5-5.6 ED II lens (example)

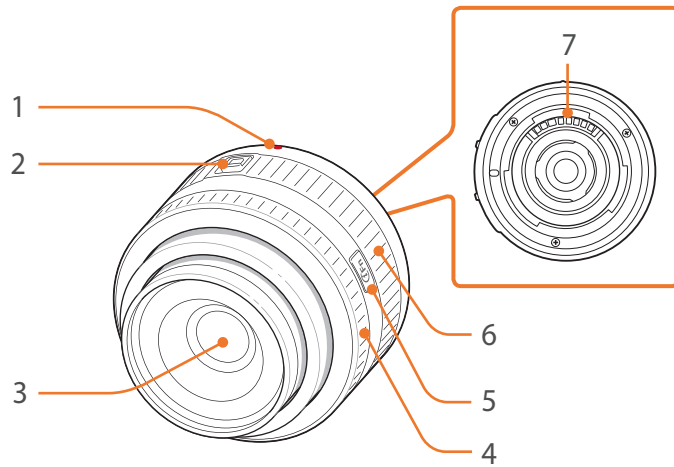

Locking or unlocking the lens

To lock the lens, slide the zoom lock switch away from the camera body, hold it in place, and then rotate the zoom ring as shown in the illustration.

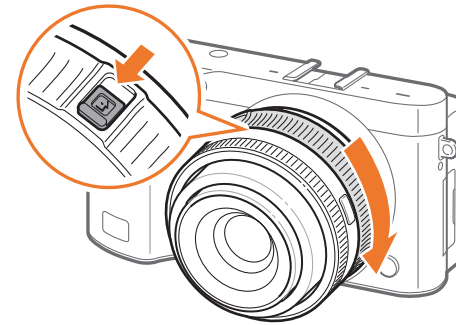

No.	Description
1	Lens mount index
2	Zoom lock switch
3	Lens
4	Focus ring (p. 96)
5	i-Function button (p. 43)
6	Zoom ring
7	Lens contacts*

* Avoid contact with or prevent damage to the lens contacts.

To unlock the lens, rotate the zoom ring as shown in the illustration until you hear the click.

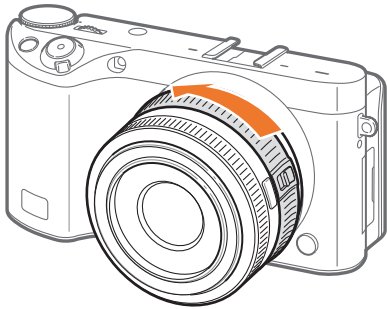

You cannot capture a photo when the lens is locked.

NX 50-150mm F2.8 S ED OIS lens (example)

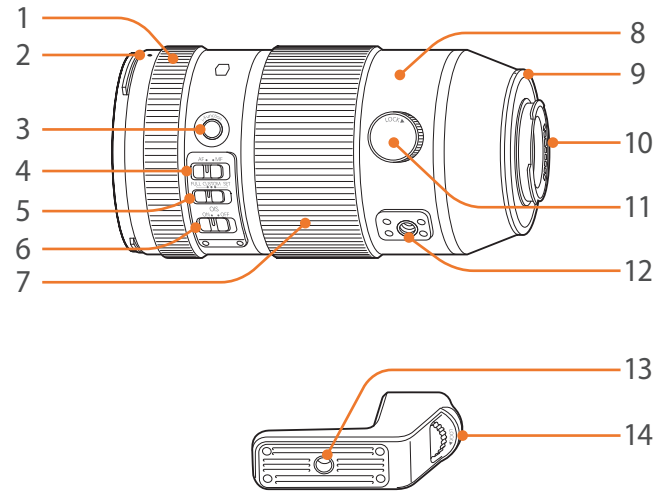

No.	Description
1	Focus ring (p. 96)
2	Lens hood mount index
3	i-Function button (p. 43)
4	AF/MF switch
5	Custom Focus Range Limiter switch
6	OIS switch

No.	Description
7	Zoom ring
8	Tripod ring
9	Lens mount index
10	Lens contacts*
11	Tripod ring locking dial
12	Tripod collar connection
13	Tripod connection
14	Tripod mount collar lock dial

* Avoid contact with or prevent damage to the lens contacts.

Using the Custom Focus Range Limiter Function

You can adjust the focus quickly and precisely by setting the range for the focus distance.

1 Set the Custom Focus Range Limiter switch to **SET**.

2 Set a focus range.

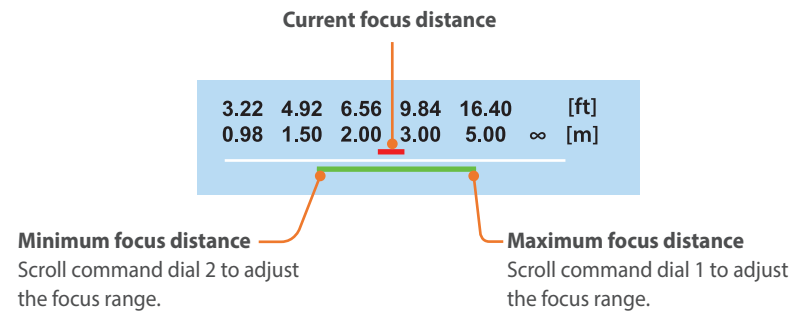

The illustration above may differ from the actual screen on your camera.

3 Set the Custom Focus Range Limiter switch to **CUSTOM** and capture a photo.

Lens markings

Find out what the numbers on the lens signify.

SAMSUNG 18-200mm F3.5-6.3 ED OIS lens (example)

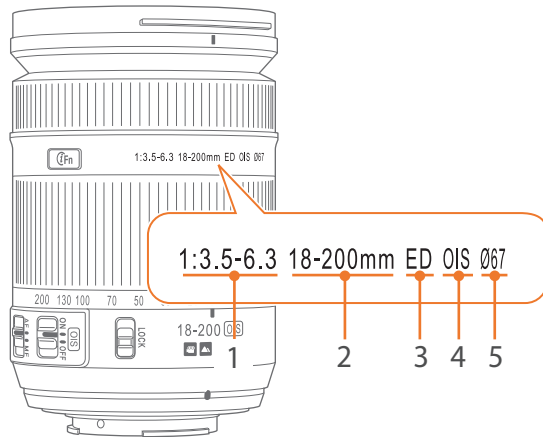

No.	Description
1	Aperture value A range of supported aperture values. For example, 1:3.5–6.3 means the aperture range is 3.5 to 6.3.
2	Focal length The distance from the middle of the lens to its focal point (in millimeters). This figure is expressed in a range: the minimum focal length to the maximum focal length of the lens. Longer focal lengths result in narrower angles of view and the subject is magnified. Shorter focal lengths result in wider angles of view.
3	ED ED stands for Extra-low Dispersion. Extra-low dispersion glass is effective in minimizing chromatic aberration (a distortion that occurs when a lens fails to focus all colors to the same convergence point).
4	OIS (Anti-Shake) (p. 99) Optical Image Stabilization. Lenses with this feature can detect camera shake and effectively cancel out the movement inside the camera.
5	Ø The lens diameter. When you attach a filter to the lens, make sure that the diameters of the lens and the filter are the same.

You can use an external flash that can help you capture better photos.

For more information about optional accessories, refer to the manual for each accessory.



- The illustrations may differ from the actual items.
- You can purchase Samsung-approved accessories at a retailer or a Samsung service center. Samsung is not responsible for damage caused by using another manufacturer's accessories.

External flash layout

SEF8A (example)

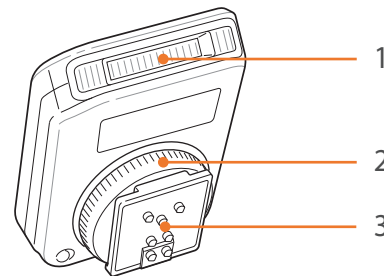

No.	Description
1	AF-assist light
2	Hot-shoe fastening dial
3	Hot-shoe connection

Connecting the external flash

1 Mount the flash by sliding it into the hot-shoe.

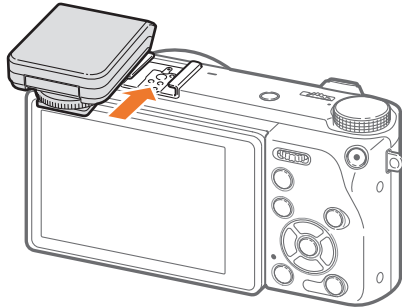

2 Lock the flash into place by turning the hot-shoe fastening dial clockwise.

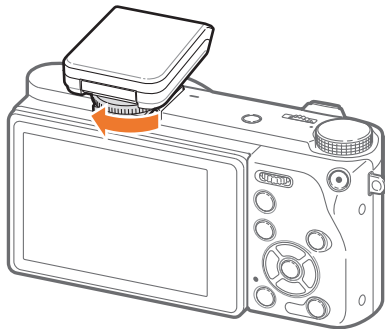

3 Lift up the flash for use.

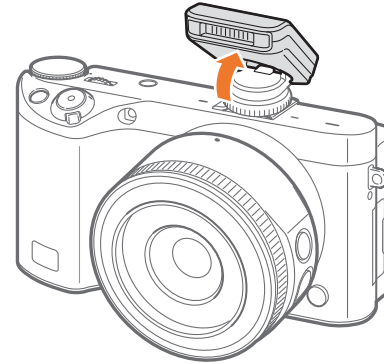

- You can capture a photo with a flash that is not fully charged, but it is recommended to use a fully charged flash.
- The available options may differ depending on the shooting mode.
- When you use Red-eye correction, there is an interval between two bursts of the flash. Do not move until the flash fires a second time.
- SEF8A may not be compatible with other NX series cameras.
- For more details about optional flashes, refer to the user manual for the flash.



Use only Samsung-approved flashes. Using incompatible flashes may damage your camera.

Shooting modes

Two simple shooting modes—Auto and Smart mode—help you capture photos with numerous automatic settings. Additional modes allow for greater customization of settings.



Icon	Description
AUTO	Auto mode (p. 60)
P	Program mode (p. 62)
A	Aperture Priority mode (p. 64)
S	Shutter Priority mode (p. 65)
M	Manual mode (p. 66)
C	Custom mode (p. 67)
SAS	Samsung Auto Shot mode (p. 69)
	Smart mode (p. 71)

AUTO Auto mode

In Auto mode, the camera recognizes surrounding conditions and automatically adjusts factors that contribute to exposure, including shutter speed, aperture value, metering, White Balance, and exposure compensation. As the camera controls most of the functions, some shooting functions are limited. This mode is useful for capturing quick snapshots with the least amount of adjustment.



- 1 Rotate the mode dial to **AUTO**.
- 2 Align your subject in the frame.

3 Half-press [Shutter] to focus.

- The camera selects a scene. An appropriate scene icon appears on the screen.

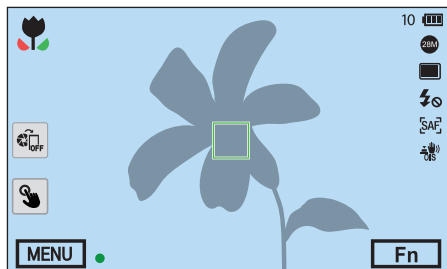

Recognizable scenes

Icon	Description
	Landscapes
	Scenes with bright white backgrounds
	Landscapes at night
	Portraits at night
	Landscapes with backlighting
	Portraits with backlighting
	Portraits
	Close-up photos of objects
	Close-up photos of text

Icon	Description
	Sunsets
	Indoors, dark
	Partially lit
	Close-up with spot lighting
	Portraits with spot lighting
	Blue skies
	Forested areas typically consist of green-colored subjects
	Close-up photos of colorful subjects
	Shooting in the dark when the camera is stabilized on a tripod and the subject does not move for a period of time.
	Actively moving subjects

4 Press [Shutter] to capture the photo.



- The camera may select different scenes and adjust settings differently, even when you aim at the same subject. Scene selection depends on external factors, such as camera shake, lighting, and distance to the subject.
- If the camera does not recognize an appropriate scene mode, it uses the default settings for the Auto mode.
- Even if it detects a face, the camera may not select a portrait mode depending on the subject's position or lighting.
- Even if you use a tripod, the camera may not detect the tripod mode if the subject is moving.
- The camera consumes more battery power, because it changes settings often to select appropriate scenes.

P Program mode

The camera automatically adjusts shutter speed and aperture value so that an optimal exposure value can be achieved.

This mode is useful when you want to capture shots of constant exposure while being able to adjust other settings.



- 1 Rotate the mode dial to P.
- 2 Set the desired options.
- 3 Half-press [**Shutter**] to focus, and then press [**Shutter**] to capture the photo.

Program Shift

The Program Shift function lets you adjust the shutter speed and aperture value while the camera maintains the same exposure. When you scroll command dial 1 or command dial 2 to the left, the shutter speed decreases and the aperture value increases. When you scroll command dial 1 or command dial 2 to the right, the shutter speed increases and the aperture value decreases.

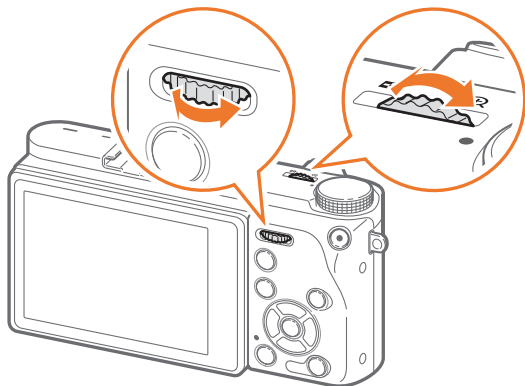

Direction	Adjustable item
←	Shutter speed decreases and aperture value increases.
→	Shutter speed increases and aperture value decreases.



You can also assign other functions to command dials 1 and 2. (p. 177)

Minimum shutter speed

Set a minimum shutter speed. However, if the camera cannot achieve an optimal exposure value because the Auto ISO Range function cannot set a higher ISO sensitivity value, then the camera will use a lower shutter speed than the minimum shutter speed you selected.

To set the minimum shutter speed,

In Shooting mode, press [MENU] →  → **Minimum Shutter Speed** → an option.



- If you select **Auto (link to focal length)**, the camera will automatically set a minimum shutter speed based on the lens' focal length. Scroll to **Auto (link to focal length)**, and then press [AF] to decrease or increase the minimum shutter speed.
- This feature is available only when ISO sensitivity is set to Auto.
- This feature is available only in Program or Aperture Priority mode.

A Aperture Priority mode

In Aperture Priority mode, the camera automatically calculates shutter speed according to the aperture value you choose.

You can adjust the depth of field (DOF) by changing the aperture value. This mode is useful for taking portraits, flowers, or landscape shots.



Large Depth of Field

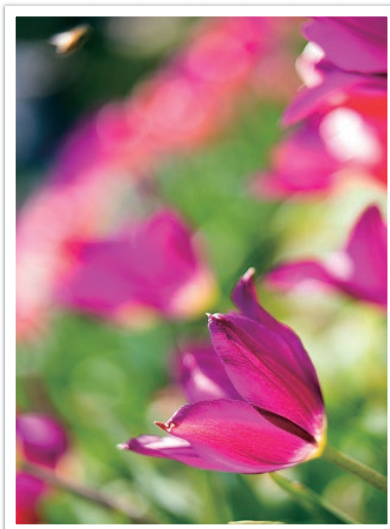

Small Depth of Field

- 1 Rotate the mode dial to **A**.
- 2 Scroll command dial 1 or command dial 2 to adjust the aperture value.
 - You can also assign other functions to command dials 1 and 2. (p. 177)
 - You can also adjust the aperture value by pressing [Fn], moving to the aperture value, and then scrolling command dial 1 or dragging your finger on the screen.
- 3 Set the desired options.
- 4 Half-press [**Shutter**] to focus, and then press [**Shutter**] to capture the photo.



- In low-light settings, you may need to increase the ISO sensitivity to prevent blurred photos.
- To set the minimum shutter speed, in Shooting mode, press [MENU] → [Camera icon] → **Minimum Shutter Speed** → an option.

S Shutter Priority mode

In Shutter Priority mode, the camera automatically adjusts the aperture value according to the shutter speed you choose. This mode is useful for capturing photos of fast-moving subjects or for creating tracer effects in a photo.

For example, set the shutter speed to over 1/500 s to freeze the subject. To make the subject appear blurred set the shutter speed to below 1/30 s.



Slow shutter speed

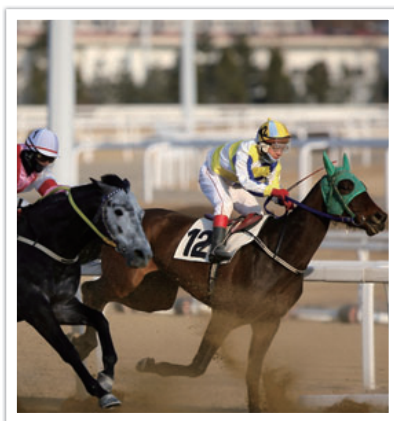

Fast shutter speed

- 1 Rotate the mode dial to S.
- 2 Scroll command dial 1 or command dial 2 to adjust the shutter speed.
 - You can also assign other functions to command dials 1 and 2. (p. 177)
 - You can also adjust the shutter speed by pressing [Fn], moving to the shutter speed, and then scrolling command dial 1 or dragging your finger on the screen.
- 3 Set the desired options.
- 4 Half-press [**Shutter**] to focus, and then press [**Shutter**] to capture the photo.



To compensate for the reduced amount of light allowed by fast shutter speeds, open the aperture and let in more light. If your photos are still too dark, increase the ISO value.

M Manual mode

Manual mode lets you adjust the shutter speed and aperture value manually. In this mode, you can fully control the exposure of your photos.

This mode is useful in controlled shooting environments, such as a studio, or when it is necessary to fine-tune camera settings. The Manual mode is also recommended for shooting night scenes or fireworks.

- 1 Rotate the mode dial to **M**.
- 2 Scroll command dials 1 and 2 to adjust the shutter speed and aperture value, respectively.
 - You can also assign other functions to command dials 1 and 2. (p. 177)
 - You can also adjust the shutter speed or the aperture value by pressing [Fn], moving to the shutter speed or the aperture value, and then scrolling command dial 1 or dragging your finger on the screen.
- 3 Set the desired options.
- 4 Half-press [**Shutter**] to focus, and then press [**Shutter**] to capture the photo.

Using the Bulb function

Use the Bulb function to shoot night scenes or the night sky. While you press and hold [**Shutter**], the shutter remains open so you can create moving light effects. To close the shutter, release [**Shutter**].

To use the Bulb function,

Completely scroll command dial 1 to the left to **Bulb** → press and hold [**Shutter**] for the desired time.







- If you set a high ISO value or open the shutter for a long time, image noise may increase.
- Drive options, flash, and One Touch Shot cannot be used with the Bulb function.
- The Bulb function is available only in Manual mode.
- Use a tripod and shutter release to prevent your camera from shaking.
- The longer you open the shutter, the longer it takes to save a photo. Do not turn the camera off while the camera saves a photo.
- To use this function for an extended period, make sure the battery is fully charged.

C Custom mode

Custom mode lets you create your own shooting modes by customizing options and saving them. Save frequently used option settings as a named Custom Mode, and then use it as your own shooting mode customized for the shooting environment. Use custom mode when you capture photos in various environments, you have preferred shooting settings, or you frequently use preset options in certain conditions.

Saving custom modes

- 1 Rotate the mode dial to P, A, S, M, or C.
- 2 Set shooting options.
- 3 Press [MENU], and then select  → **Manage Custom Mode** → **Save**.
 - You can also save a custom mode by touching  or  → **Save** on the screen.

- 4 Verify the shooting options, and then select **Save** or **Save as**.
- 5 Use the on-screen keyboard to enter a name for the mode. (p. 156)
- 6 Press [>] to save the mode name.
- 7 Capture a representative photo for the mode to save.
- 8 Select **Save**.



You can save up to 40 custom modes.

Downloading custom modes

You can download various shooting settings (film) to a smart phone and share them with the camera. (p. 151)

- 1 Connect the camera and a smart phone via Bluetooth.
- 2 On the smart phone, turn on Samsung Camera Manager.
- 3 Select **Pro Suggest Market**.
- 4 Download a desired film.
 - Downloaded films are saved to the camera as custom modes.



- The custom mode saved on the camera is automatically shared to a smart phone when the camera and a smart phone are connected.
- Some of the shooting settings (film) may not be supported on the camera.

Selecting custom modes



- 1 Rotate the mode dial to **C**.
- 2 On a pop-up window, select **Yes** → a mode.
 - You can also press [MENU], and then select ⌂ → **Manage Custom Mode** → **Open** → a mode.
 - You can also touch  on the screen and select **Open** → a mode.
 - If there are no custom modes saved, you can select a shooting mode from a pop-up window on the camera, set shooting options, and then save new custom modes.
- 3 Verify the shooting options, and then select **OK**.

Deleting custom modes

- 1 Rotate the mode dial to **P**, **A**, **S**, **M**, or **C**.
- 2 Press [MENU], and then select ⌂ → **Manage Custom Mode** → **Delete** → **Multiple Delete**.
 - To delete all the saved custom modes, select **Delete All**, and then select **Yes** when the pop-up message appears.
- 3 Select a mode to delete, and then press [].

SAS Samsung Auto Shot mode

In Samsung Auto Shot, you can capture action photos, such as someone hitting a baseball, making a jumpshot, or passing a preset point.

- 1 Rotate the mode dial to SAS.
- 2 Touch , , or , and then select **Baseball, Jump Shot, or Trap Shot**.
- 3 Press [**Shutter**] to capture a photo.
 - The camera takes photos continuously when it detects the subject's movement.
 - Press [MENU] to stop capturing.



- Use a tripod to prevent your camera from shaking.
- In dark environments, the camera may not capture the movements of subjects properly.
- You can only select a 3:2 photo size.

When Jump Shot is selected

Focus on the subject and start capturing. The camera automatically takes the photo when it detects the jumping subject at its highest point. You can also select and focus on an area that you touch on the screen.



- The camera may take the photo using the person jumping highest as a reference when many people are jumping.
- The camera may not take the photo properly under the following conditions:
 - The height of the subject is less than 50 % of the angle of view from the vertical reference.
 - The jumping action is not sufficiently distinct to be recognized by the camera.

When Baseball is selected

The camera automatically takes the photo when it detects a ball at the estimated hitting point that you set by positioning a vertical line on the screen.

To position the hitting point, drag the vertical line on the screen, scroll command dial 1 or 2.

To change the location of the batter and the ball, tap and drag the vertical line to the batter's location facing the pitcher. You cannot drag the line into the opaque area on the screen.

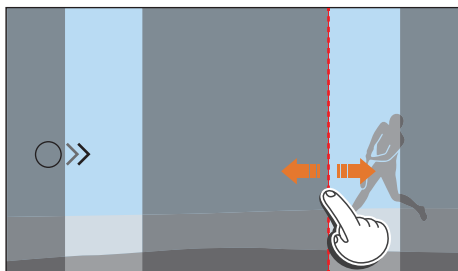

- The camera may not take the photo properly under the following conditions:
 - When shooting outside of a $\pm 20^\circ$ angle of view from a batter's side (in the direction of a ball's path).
 - When the estimated hitting point is outside of the selectable area.
 - If there is a net or fence between you and the subject.
- The camera may take a photo even when it does not detect a ball, such as when the subject is backlit, when you take photos indoors, or when you take photos without using a tripod.

When Trap Shot is selected

The camera takes photos continuously when it detects the subject moving in the direction of the arrow at the vertical line that you set on the screen.

To position the vertical line on the screen, drag the arrow icon on the vertical line to the desired point, scroll command dial 1 or 2.

You can also touch the area on the screen where the subject is expected to pass through or manually adjust the focus by rotating the focus ring after half-pressing [**Shutter**].



- When you select Trap Shot, the Direct Manual Focus (DMF) function is automatically set.
- When you select Trap Shot, the AF mode is set to Single AF and the AF area is set to Selection AF.
- The area where the subject is expected to pass through must be in focus.
- You cannot drag the line into the opaque area of the screen.
- Subjects that are moving in the same direction may not be detected properly depending on the angle of view or the size of the subjects.
- The camera may not take the photo properly under the following conditions:
 - When the size of the subject is too small.
 - When the subject is moving too quickly.
 - When there are moving objects in the background.
 - When you take photos in dark, indoor areas, such as an indoors sports complex.

S Smart mode

In Smart mode, you can capture photos with preset parameters when shooting specific scenes, conditions, or effects.

1 Rotate the mode dial to **S**.

2 Select a scene.

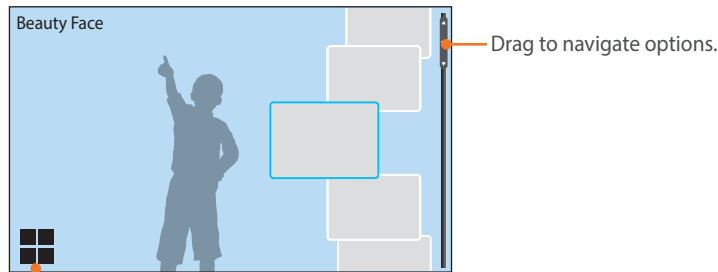

Switch to the grid view.

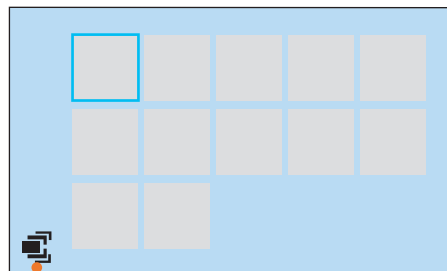

Switch to the list view.

Option	Description
Beauty Face	Capture a portrait with options to hide facial imperfections.
Landscape	Capture still-life scenes and landscapes.
Action Freeze	Capture subjects moving at high speed.
Rich Tones	Capture a photo with vibrant colors.
Panorama	Capture a wide panoramic scene in a single photo.
Waterfall	Capture scenes with waterfalls.
Multi Exposure	Capture multiple photos and overlap them to create one photo.
Silhouette	Capture subjects as dark shapes against a light background.
Sunset	Capture scenes at sunset, with natural-looking reds and yellows.
Night	Capture a photo with less blurring and visual noise.
Fireworks	Capture scenes with fireworks.
Light Trace	Capture scenes with the light trailing in low-light conditions.

3 Half-press [**Shutter**] to focus, and then press [**Shutter**] to capture.

Capturing panoramic photos

In Panorama mode, you can capture a wide panoramic scene in a single photo. Panorama mode captures and combines a series of photos to create a panoramic image.

1 Rotate the mode dial to **S**, and then select **Panorama**.

2 Press and hold [**Shutter**] to start shooting.

3 With [**Shutter**] pressed, slowly move the camera in the direction you selected.

- An arrow pointing in the direction of motion is displayed, and the entire shooting image is displayed in the preview box.
- When the scenes are aligned, the camera captures the next photo automatically.



4 When you are finished, release [**Shutter**].

- The camera will automatically save the shots into one photo.
- If you release [**Shutter**] while shooting, the panoramic shooting stops and photos that have been captured are saved.



- The resolution varies depending on the panoramic photo you captured.
- In Panorama mode, some shooting options are not available.
- The camera may stop shooting due to the shooting composition or the subject's movement.
- In Panorama mode, the camera may not capture the entire scene if you stop moving the camera when the end of the scene appears in the camera's screen. To capture the entire scene, move your camera slightly beyond the point where you want the scene to end.
- For best results when capturing panoramic photos, avoid the following:
 - moving the camera too quickly or too slowly
 - moving the camera too little to capture the next image
 - moving the camera at irregular speeds
 - shaking the camera
 - shooting in dark places
 - capturing moving subjects nearby
 - shooting conditions where the brightness or color of light is changing
- Photos taken are automatically saved, and shooting is stopped under the following conditions:
 - If you change the shooting direction while shooting.
 - If you move the camera too rapidly.
 - If you do not move the camera.

Recording a video

In Shooting mode, you can record 4K videos (up to 4096X2160) by pressing  (Video recording). (p. 192) The camera saves video in HEVC format. When you record a video at 640X480 (MJPEG), the video will be saved in AVI format. To view HEVC files, you must have a device or program with HEVC codecs installed. Sound is recorded via the camera's microphone.

You can set the exposure by adjusting the aperture value and shutter speed for the mode you selected. When you use a lens that does not have an AF/MF switch while recording a video, press [AF] to select a desired AF mode. If the lens has an AF/MF switch, set the switch according to the selected focus mode. Set the switch to AF when you select Single AF or Continuous AF. Set the switch to MF when you select Manual Focus.

Press [Fn] to switch between AF and MF while recording a video. Press the AEL button to use the focus lock function (when the AFL function is assigned to the AEL button).

Select **Fader** to fade a scene in or out. You can also select **Voice, Wind Cut**, or other options. (p. 123)

While recording a video, touch  to select a touch AF option. If you select **Touch AF**, you can hold the camera's focus on a subject by touching the subject on the screen. If you select **Tracking AF**, the focus tracks and automatically focuses on your subject, even when the subject is moving or when you change the picture composition.

1 Set the desired options.

- If [CUSTOM] is set to **Movie STBY**, press [CUSTOM] to enter the Video recording standby mode.
- In the Video recording standby mode, the video function stays on after recording has finished. To return to Shooting mode, press [**Shutter**].

2 Press (Video recording) to start recording.

- Video recording may not be supported depending on the selected shooting options.

3 Press (Video recording) again to stop.



- High-efficiency Video Coding (HEVC) is the latest video encoding format established in 2013 collaboratively by ISO-IEC and ITU-T. Because this format uses a high compression rate, more data can be saved in less memory space. Depending on your computer's specifications and interface, files may not play at full resolution due to the high compression rate on some computers. To view the file in HEVC format, you need a device or program with installed HEVC codecs.
- When recording 4K or UHD video, the angle of view becomes narrower. (Effective angle of view: approx. 4K 1.68 times, UHD 1.77 times the focal length)
- If you have the image stabilizer option on when shooting a movie, the camera may record the sound of the image stabilizer working.
- When recording a video, the camera may record the sounds of the zoom or other lens adjustments.
- When using an optional video lens, the autofocus noise is not recorded.
- If you remove the camera lens while recording a movie, the recording will be interrupted. Do not change the lens while recording.

- You can set the ISO sensitivity up to ISO 6400 when recording a video.
- If you change the shooting angle of the camera suddenly while shooting a movie, the camera may not be able to record images accurately. Use a tripod to minimize camera shake.
- When formatting a memory card, always format using the camera. When you format a memory card with a capacity of 32 GB or less on the camera, the file system is changed to FAT32. When you format a memory card with a capacity of 64 GB or more, the file system is changed to exFAT. If you format on another camera or a PC, you can lose files on the card or cause a change in the capacity of the card.
- When using a memory card formatted as FAT32, the camera will automatically stop recording when the size of a video exceeds 4 GB, even if the maximum recording time has not been reached. Using a memory card formatted as exFAT allows you to record a video for the maximum recording time, regardless of the video's file size. The maximum recording time is 29 minutes and 59 seconds.
(When you select 1920X1080 (60p/50p), the maximum recording time is 25 minutes. When you select 4096X2160, 3840X2160, or 640X480 (MJPEG), the maximum recording time is 15 minutes.)
- If you use a slow writing memory card, the recording of your movie can be interrupted because the card cannot process data at the rate the video is being shot. If this occurs, replace the card with a faster memory card or reduce the video size (for example, from 1280X720 to 640X480).
- When recording a UHD video, we recommend you use a memory card with a write speed greater than 30 MB/sec.
- When you press the video recording button, intelli-zoom turns off.
- Videos can be darker than photos recorded at the same ISO sensitivity. If the videos appear darker, adjust the ISO sensitivity.
- When you record a video in P, A, or S mode, ISO is automatically set to **Auto**.
- Touching the screen to select a focus area while recording with Continuous AF switches the AF mode to Single AF.
- The Focus Peaking function is not available when you select a resolution of 4096X2160 or 3840X2160.
- If the camera overheats while recording, the overheating warning icon will display on the screen. The camera will automatically save the video and stop recording. Cool down the camera to continue recording.



3D mode

You can capture 3D photos or videos with an optional 3D lens.

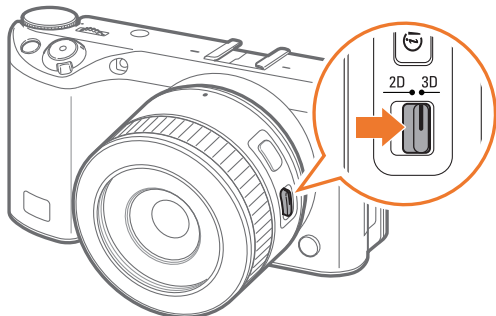

SAMSUNG 45mm F1.8 [T6] 2D/3D lens (example)

Set the 2D/3D switch on the lens to **3D**, and then capture a photo or video 5 to 16.25 ft. (1.5–5 m) away from the subject.

- 3D mode is always on, regardless of the mode dial of the camera.
- To use auto 3D options that enable the camera to set shooting options automatically depending on shooting conditions in 3D mode, press [MENU] →  → **3D Auto mode** → **On**.



- Available shooting options differ compared to other shooting modes.
- You can select either the 5.9M (3232X1824) or 2.1M (1920X1080) photo size.
- The video resolution is set to 1920X1080.
- Videos recorded in 3D may be dark or playback may be jittery.
- Shooting in low temperatures may result in color distortion in images and may consume more battery power.
- You may not be able to shoot properly in conditions below 8.5 LV/900 lux. For best results, capture photos in places with sufficient light.
- When you photograph objects that contain polarizing material, such as a display, sunglasses, or a polarizing filter, or use polarizing material with your lens, the images may appear dark or the 3D effect may not be applied properly.
- Use a tripod to prevent your camera from shaking.
- If you rotate or tilt the camera vertically while shooting, the 3D effect may not be applied properly. Capture images with the camera in the normal position.
- If you shoot in fluorescent lighting or capture images displayed by projectors or TVs, the images may appear black due to the flicker effect.
- In 3D mode, the **Enlarge x8** option of **MF Assist** may not be available.
- The camera's display shows 3D videos only in 2D.
- Photos captured with the 3D function are saved in JPEG (2D) and MPO (3D) formats. On your camera's display, you can view only JPEG files.
- To view 3D files, connect your camera to a 3D TV or 3D monitor with an optional HDMI cable. While viewing, wear proper 3D glasses.
- You cannot use the flash in 3D mode.

Available functions by shooting mode

For details about shooting functions, see Chapter 2.

You can press shortcut buttons to access selected functions as noted.

Function	Available in	Shortcut
Framing Mode (p. 115)	P/A/S/M	-
Photo Size (p. 78)	P/A/S/M/ S */ AUTO */ 3D *	-
Quality (p. 79)	P/A/S/M/ S *	-
ISO (p. 80)	P/A/S/M	Fn/ISO
OLED Color (p. 82)	P/A/S/M/ S / AUTO / 3D	-
White Balance (p. 83)	P/A/S/M	Fn
Picture Wizard (p. 85)	P/A/S/M	Fn
Smart Filter (p. 86)	P/A/S/M	-
AF Mode (p. 87)	P/A/S/M/ S */ AUTO / 3D *	Fn/AF
AF Area (p. 90)	P/A/S/M/ S *	Fn
Touch AF (p. 94)	P/A/S/M/ S */ AUTO */ 3D *	-
MF Assist (p. 96)	P/A/S/M/ S / AUTO / 3D *	-

Function	Available in	Shortcut
Focus Peaking (p. 98)	P/A/S/M/ S / AUTO	-
OIS (Anti-Shake) (p. 99)	P/A/S/M/ S */ AUTO	-
Drive (Single/Continuous/ Burst/Timer/Bracketing) (p. 100)	P/A/S/M/ S */ AUTO */ 3D *	Fn/ 
Interval Capture (p. 105)	P/A/S/M	-
Flash (p. 106)	P*/A*/S*/M*/ S */ AUTO *	Fn
Metering (p. 111)	P/A/S/M	Fn
Link AE to AF Point (p. 113)	P/A/S/M	-
Dynamic Range (p. 114)	P/A/S/M	-
Exposure compensation (p. 115)	P/A/S/M/ S *	Fn
Exposure/Focus lock (p. 117)	P/A/S	AEL

* Some functions are limited in these modes.



Chapter 2

Shooting Functions

Learn about the functions you can set in Shooting mode.
You can enjoy more customized photos and videos by using the shooting functions.

Size and Resolution

Photo size













As you increase the resolution, your photo or video will include more pixels, so it can be printed on larger paper or displayed on a larger screen. When you use a high resolution, the file size will also increase. Select a low resolution for photos that will be displayed in a digital picture frame or uploaded to the web.



To set the size,

In Shooting mode, press [MENU] →  → **Photo Size** → an option.

* Default

Icon	Size	Recommended for
	(3:2) 6480X4320*	Printing on A0 paper.
	(3:2) 4560X3040	Printing on A2 paper.
	(3:2) 3264X2176	Printing on A3 paper.
	(3:2) 2112X1408	Printing on A5 paper.
	(16:9) 6480X3648	Printing on A0 paper or viewing on an HDTV.
	(16:9) 4608X2592	Printing on A2 paper or viewing on an HDTV.
	(16:9) 3328X1872	Printing on A4 paper or viewing on an HDTV.
	(16:9) 2048X1152	Printing on A5 paper or viewing on an HDTV.
	(1:1) 4320X4320	Printing a square photo on A2 paper.
	(1:1) 3088X3088	Printing a square photo on A3 paper.
	(1:1) 2160X2160	Printing a square photo on A4 paper.
	(1:1) 1408X1408	Printing a square photo on A5 paper.



Available options may differ depending on shooting conditions.

Quality

The camera saves photos in either the JPEG or RAW format.

Photos captured by a camera are often converted to the JPEG format and stored in the memory according to the settings of the camera at the time of shooting. RAW files are not converted to the JPEG format and are stored in the memory without any changes.

RAW files have the file extension “SRW”. To adjust and calibrate exposures, White Balances, tones, contrasts, and colors of the RAW files, or to convert them into JPEG or TIFF format, use the supplied Samsung RAW Converter program.







As RAW files are very large, ensure there is enough space on the memory card to save them in this format.

To set the quality,

In Shooting mode, press [MENU] →  → **Quality** → an option.

Icon	Format	Description
	JPEG	<p>Super Fine*:</p> <ul style="list-style-type: none"> Compressed for the best quality. Recommended for printing in large sizes.

* Default

Icon	Format	Description
	JPEG	<p>Fine:</p> <ul style="list-style-type: none"> Compressed for better quality. Recommended for printing in normal sizes.
	JPEG	<p>Normal:</p> <ul style="list-style-type: none"> Compressed for normal quality. Recommended for printing in small sizes or for uploading to the web.
	RAW	<p>RAW:</p> <ul style="list-style-type: none"> Save an unprocessed version of the photo. Recommended for editing after shooting.
	RAW+JPEG	<p>RAW + S.Fine: Save a photo in both the JPEG (S.Fine quality) and RAW format.</p>
	RAW+JPEG	<p>RAW + Fine: Save a photo in both the JPEG (Fine quality) and RAW format.</p>
	RAW+JPEG	<p>RAW + Normal: Save a photo in both the JPEG (Normal quality) and RAW format.</p>

* Default



Available options may differ depending on shooting conditions.

ISO sensitivity

The ISO sensitivity value represents the sensitivity of a camera to light.

The larger the ISO value, the more sensitive the camera is to light. Consequently, by selecting a higher ISO sensitivity value, you can capture photos in dim or dark places at faster shutter speeds. However, this may increase electronic noise and result in a grainy photo.

To set ISO sensitivity,

In Shooting mode, press [ISO] → an option.

Examples

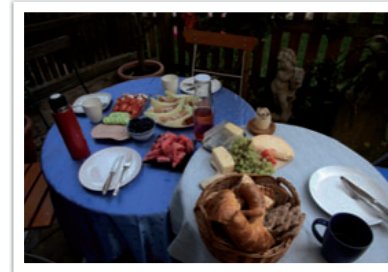

ISO 100



ISO 400



ISO 800



ISO 3200



- You can also set the option by pressing [MENU] →  → **ISO** → an option in Shooting mode.
- Increase the ISO value in places where flash use is prohibited. You can capture a clear photo by setting a high ISO value without having to secure more light.
- Use the Noise Reduction function to reduce the visual noise that can appear on photos taken at high ISO values. (p. 171)
- Available options may differ depending on the shooting conditions.
- You can set the ISO sensitivity up to ISO 6400 when recording a video.

Customizing ISO settings

Set to adjust ISO Step, Auto ISO Range, or ISO Expansion.

To customize ISO settings,

In Shooting mode, press [MENU] →  → **ISO Customizing** → an option.

Option	Description
ISO Step	You can set the size of ISO sensitivity adjustments to either 1/3 step or 1 step.
Auto ISO Range	You can set the maximum ISO value the camera will use to set each EV step when you set the ISO to Auto.
ISO Expansion	You can select ISO 51200.



You can select up to ISO 25600 when using **Continuous Normal** or up to ISO 6400 when using **Continuous High**.



OLED Color

Set the camera to optimize colors for playback on OLED displays. An OLED display has a wider color reproduction range than a liquid crystal display and produces brighter, natural colors.

To set OLED Color,

In Shooting mode, press [MENU] →  → **OLED Color** → an option.

Examples



Without OLED Color effect



With OLED Color effect



White Balance

The White Balance function adjusts the color in photos to give them a more natural appearance. You can use this function if color is affected by the type and quality of the light source. For example, fluorescent lamps can give colors in a photo a bluish hue. To offset this effect, select a White Balance option that adjusts the camera's settings for the light source. You can also adjust the White Balance by manually adjusting the camera's Color Temperature setting.

In addition, you can also customize the preset White Balance options so that the colors of the photo match the actual scene under mixed lighting conditions.







To set the White Balance,

In Shooting mode, press [MENU] →  → **White Balance** → an option.

Icon	Description
AWB	Auto WB* : Automatically adjust the white balance settings for the light source.
	Auto WB+Tungsten : Automatically adjust the white balance settings for the light source except when shooting under incandescent or halogen lamps. This option does not offset the reddish hue of incandescent or tungsten bulbs.
	Daylight : Select when taking outdoor photos on a sunny day. This option results in photos closest to the natural colors of the scene.
	Cloudy : Select when taking outdoor photos on a cloudy day or in shadows. Photos captured on cloudy days tend to be more bluish than on sunny days. This option offsets that effect.

* Default

* Default

Icon	Description
	Fluorescent White : Select when shooting under a daylight fluorescent lamp with a white hue.
	Fluorescent NW : Select when shooting under a daylight fluorescent lamp with a very white hue.
	Fluorescent Daylight : Select when shooting under a daylight fluorescent lamp with a slightly bluish hue.
	Tungsten : Select when taking indoor photos under incandescent bulbs or halogen lamps. Incandescent tungsten bulbs tend to have a reddish hue. This option offsets that effect.
	Flash WB : Select when using a flash.
	Custom Set : Use your pre-defined settings. You can manually set the White Balance by pressing [DISP], and then shooting a white sheet of paper. Fill the spot metering circle with the paper and set the White Balance.
	Color Temperature : Manually adjust the color temperature of the light source. Color temperature is a measurement in degrees Kelvin that indicates the specific type of light source. You can get a warmer photo with a higher value, and a cooler photo with a lower value. Press [DISP], and then adjust the color temperature.



Available options may differ depending on shooting conditions.

Customizing preset White Balance options

You can also customize preset White Balance options.

To customize preset options,

In Shooting mode, press [MENU] → → **White Balance** → an option → [DISP] → scroll command dials 1 or 2 or press [DISP/ISO//AF].

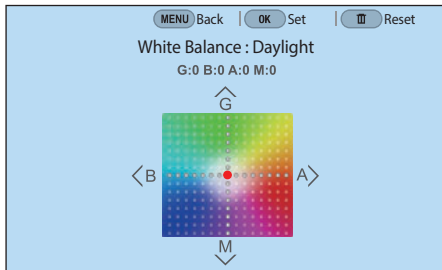

You can also touch an area on the screen.

Examples



Auto WB



Daylight



Fluorescent Daylight

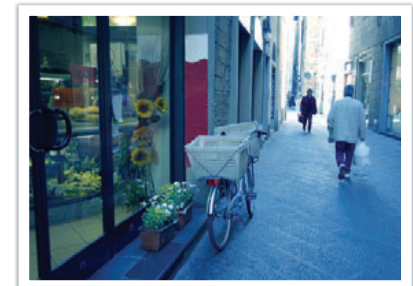

Tungsten

Picture Wizard (photo styles)

Picture Wizard lets you apply different photo styles to your photo to create various looks and emotional moods. You can also create and save your own photo styles by adjusting color, saturation, sharpness, contrast, and hue for each style.

There is no rule that determines which style is suitable in which conditions. Experiment with different styles and find your own settings.

To set a photo style,

In Shooting mode, press [MENU] →  → **Picture Wizard** → an option.

Examples



Standard

Classic

Vivid



Portrait

Landscape

Forest







Retro

Cool

Calm



- You can also adjust the value of the preset style settings. Select a Picture Wizard option, press [DISP], and then adjust color, saturation, sharpness, contrast, or hue.
- To customize your own picture wizard, select , , or  and then adjust the color, saturation, sharpness, and contrast.
- You can use  (Custom Pro) in C mode after you download the shooting settings (film) via a smart phone. (p. 68)
- Picture Wizard options cannot be set with Smart Filter options at the same time.

Smart Filter

Smart Filter lets you apply special effects to your photos. You can select various filter options to create special effects that are difficult to achieve with normal lenses.

To set Smart Filter options,

In Shooting mode, press [MENU] →  → **Smart Filter** → an option.

Option	Description
Off*	No effect
Vignetting	Apply the retro-looking colors, high contrast, and strong vignette effect of Lomo cameras.
Miniature (H)	Apply a tilt-shift effect to make the subject appear in miniature. The top and bottom of the photo will be blurred.
Miniature (V)	Apply a tilt-shift effect to make the subject appear in miniature. The left and right of the photo will be blurred.
Watercolor	Apply a watercolor painting effect.
Red	Desaturate all colors but red.

* Default

Option	Description
Green	Desaturate all colors but green.
Blue	Desaturate all colors but blue.
Yellow	Desaturate all colors but yellow.

* Default



- You cannot set Smart Filter options and Picture Wizard options at the same time.
- Available options may differ depending on the shooting conditions.

AF mode

Learn how to adjust the camera's focus according to the subjects.

You can select the appropriate focus mode for the subject: Single Auto Focus, Continuous Auto Focus, Active Auto Focus, or Manual Focus. The AF function is activated when you press [**Shutter**] halfway. In the MF mode, you have to rotate the focus ring on the lens to focus manually.

In most cases, you can make the camera focus by selecting **Single AF**. Fast moving subjects or subjects with small shading differences in the background are difficult to focus. Select an appropriate focusing mode for such instances.

If your lens has an AF/MF switch, you must set the switch according to the selected mode. Set the switch to AF when you select Single AF, Continuous AF, or Active AF. Set the switch to MF when you select Manual Focus.

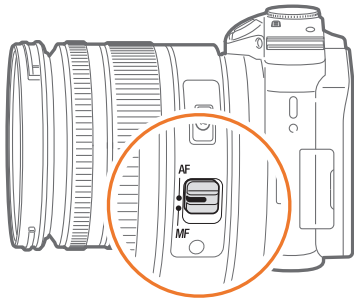

When your lens has no AF/MF switch, press [**AF**] to select a desired AF mode.

To set the auto focus mode,

In Shooting mode, press [**AF**] → an option.



- You can also set the option in Shooting mode by pressing [**MENU**] →  → **AF Mode** → an option.
- The available options may differ depending on the lens in use.

Single AF

Single AF is appropriate for shooting a still subject. When you press **[Shutter]** halfway, the focus fixes in the focus area. The area turns green when the focus is achieved.



Continuous AF

While you press **[Shutter]** halfway, the camera continues to focus automatically. This mode is recommended for shooting action.



- Depending on the type of lens, auto focus results may differ when you capture photos continuously using Continuous AF. Use an optional lens for smooth auto focus operation. Select an optional lenses from the following:
 - SAMSUNG 16-50mm F2-2.8 S ED OIS
 - SAMSUNG 16-50mm F3.5-5.6 Power Zoom ED OIS
 - NX 50-150mm F2.8 S ED OIS
- When using **Continuous AF** and **Multi AF**, press **[AF-ON]** to resize or move the focus area while shooting. Use command dial 2 to move the focus area. Scroll command dial 1 to resize the focus area. When you press **[Shutter]** halfway, the camera focuses only on the set focus area. The focus area moves with the subject after the focus is set correctly.

Active AF

While you press **[Shutter]** halfway, the camera automatically detects the subject's movements and switches between Single AF and Continuous AF. It fixes the focus on the subject when the subject gets far from the camera (Single AF). It continues to focus automatically when the subject gets closer to the camera (Continuous AF). This mode is recommended for shooting subjects that are moving unpredictably.

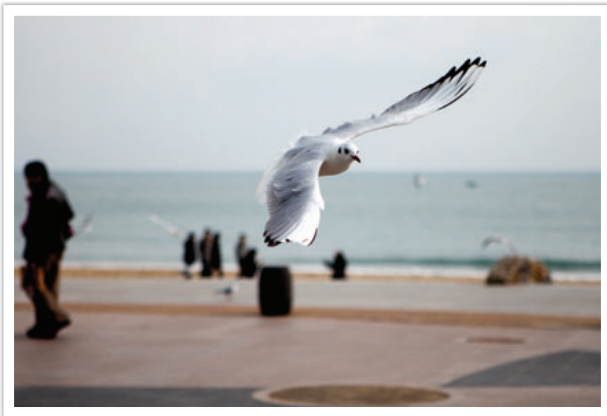

This option is not available when the camera is recording a video.

Manual focus

You can manually focus on a subject by rotating the focus ring on the lens. The MF Assist function lets you easily bring a subject into focus. While you are rotating the focus ring, the focus area is magnified. When you use the Focus Peaking function, the color you selected appears on the focused subject. This mode is recommended for shooting a subject similar in color to the background, a night scene, or fireworks.



If you use this function, you cannot set **Touch AF**, **AF Area**, **Face Detection**, and **Link AE to AF Point** options.

AF area

The AF area function changes the positions of the focus area.

Generally, cameras focus on the nearest subject. When there are multiple subjects, however, unwanted subjects can be in focus. To prevent unwanted subjects from being in focus, change the focus area so that a desired subject is in focus. You can get a clearer and sharper photo by selecting an appropriate focus area.

To set the auto focus area,

In Shooting mode, press [MENU] →  → **AF Area** → an option.



- Available options may differ depending on shooting conditions.
- When the AF/MF switch is set to **MF**, you cannot change the AF area from the shooting menu.

Selection AF

You can set the focus on an area you want. Apply an out-of-focus effect to make the subject more distinguishable.

The focus on the photo below was repositioned and resized so that it fits the subject's face.

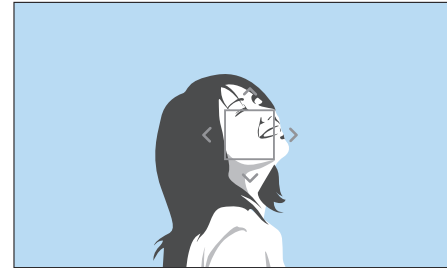

To resize or move the focus area, in Shooting mode, press [OK]. Use command dial 2 to move the focus area. Scroll command dial 1 to resize the focus area.

Saving Selection AF position

You can set the camera to remember the most recent AF position used by Selection AF and Touch AF before turning the camera off.

To set this function,

In Shooting mode, press [MENU] →  → **Save Selection AF Position** → an option.

Zone AF

The camera focuses only on the area that you set. The focus area remains locked on the set area even when the subject leaves the focus area. This mode is recommended for when you want to fix the focus on the specific area.

To resize or move the focus area, in Shooting mode, press [OK].

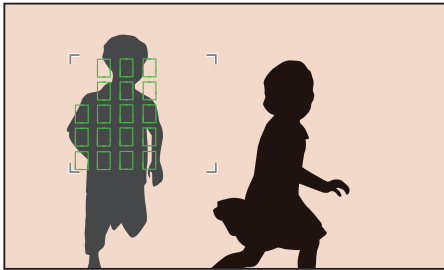

Multi AF

The camera displays a green rectangle in places where the focus is set correctly. The photo is divided into two or more areas, and the camera obtains focus points in each area. This mode is recommended for taking photos of scenery.

When you press [**Shutter**] halfway, the camera displays the focus areas as shown in the photo below.

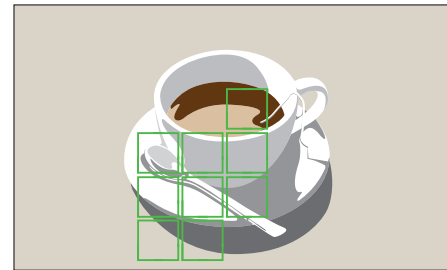

Face Detection

Use Face Detection options to capture a self portrait or a smiling face.

To use the face detection function,

In Shooting mode, press [MENU] →  → **Face Detection** → an option.



- When your camera detects a face, it tracks the detected face automatically.
- Depending on the Picture Wizard options, Face Detection may not be effective.
- When you set manual focus, Face Detection may not be available.
- Face Detection may fail if:
 - the subject is too close or too far from the camera
 - it is too bright or too dark
 - the subject is not facing the camera
 - the subject is wearing sunglasses or a mask
 - the subject's facial expression changes drastically
 - the subject is backlit or the lighting conditions are unstable
- When you set Face Detection options, the AF area is automatically set to Multi AF.
- Depending on the Face Detection options you selected, some shooting options may not be available.

Normal

The camera focuses on human faces preferentially and can detect the faces of up to 10 people. This setting is recommended for shooting a group of people.

When you press [**Shutter**] halfway, the camera focuses on faces as shown in the photo below. When you photograph a group of people, the camera displays the white focus square on the nearest person's face or on the face of the person in the center of the screen. It displays gray squares on the rest of the faces.

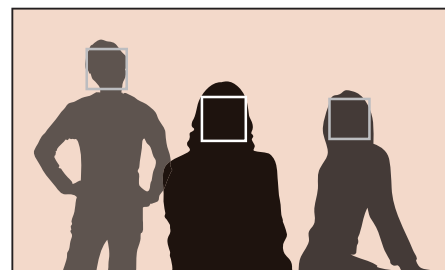

Smile Shot

The camera automatically releases the shutter when it detects a smiling face.

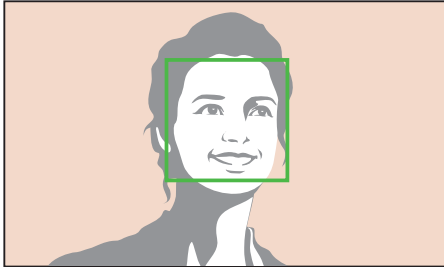

When your subject smiles broadly, your camera can detect the smile more easily.

Wink Shot

The camera automatically releases the shutter 2 seconds after it detects a winking face.

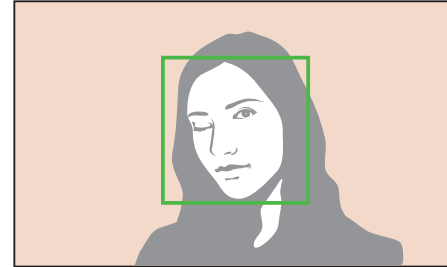

- Wink for more than 1 second for better detection.
- Wink detection may fail if:
 - the camera is below eye level
 - the subject appears dark due to backlighting
 - the subject is wearing glasses

Touch AF

Select or focus on an area that you touch on the screen. Additionally, focus on the subject and capture a photo by touching the screen.

To set Touch AF,

In Shooting mode, press [MENU] →  → **Touch AF** → an option.



Available options may differ depending on the shooting conditions.

Touch AF

Touch AF allows you to select and focus on the focus area that you touch on the screen.

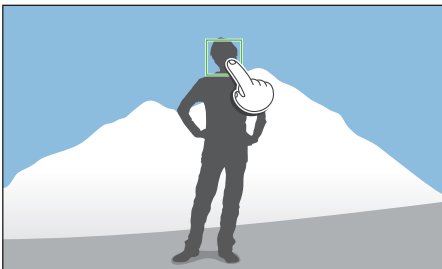

AF Point

The focus area will correspond to the area you touch on the screen and the focus will not be achieved.

Tracking AF

Tracking AF allows you to track and automatically focus on your subject, even when the subject is moving or when you change the shooting composition.

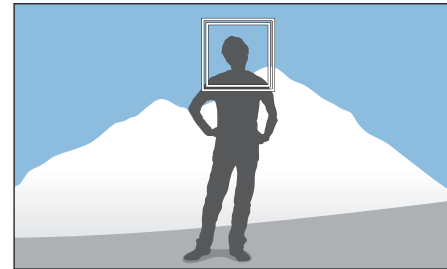

White frame: Your camera is tracking the subject.

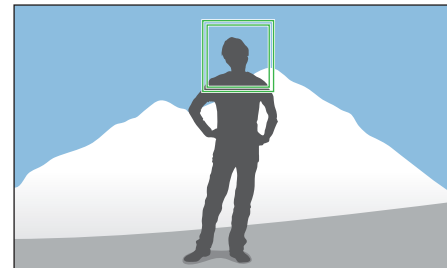

Green frame: Your subject is in focus when you half-press [Shutter].

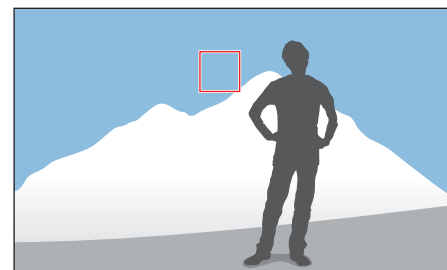

Red frame: Your camera failed to focus.



- If you do not select a focus area, the Auto Focus function does not work.
- Tracking a subject may fail if:
 - The subject is too small.
 - The subject moves irregularly.
 - The subject is backlit or you are shooting in a dark place.
 - Colors or patterns on the subject and the background are the same.
 - The subject includes horizontal patterns, such as blinds.
 - The camera shakes excessively.
 - You capture photos continuously.
- When tracking fails, the feature will be reset.
- If the camera fails to track the subject, the focus area will be reset.
- If the camera fails to focus, the focus frame will change to red and the focus will be reset.
- When you select Tracking AF, the AF mode is set to Continuous AF.

One Touch Shot

You can capture a photo with the touch of your finger. As you touch a subject, the camera focuses on the subject automatically and captures a photo.

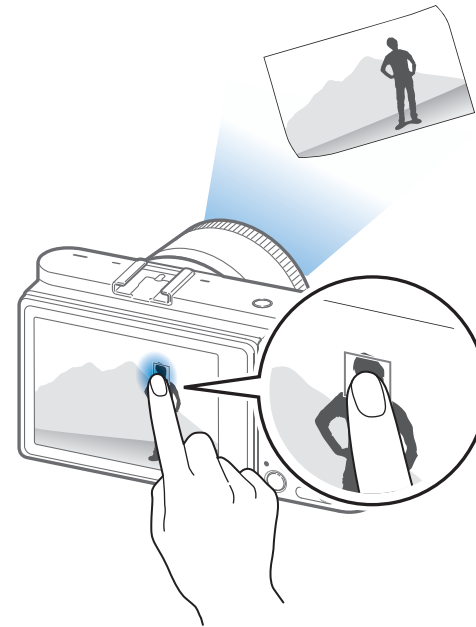

Focus assist

Use various focus assist functions while focusing the camera automatically or manually. Manual focus assist functions are available only with lenses that support manual focus.



MF Assist

In the manual focus mode, you can enlarge the scene and easily adjust the focus while rotating the focus ring.

To set the manual focus assist,

In Shooting mode, press [MENU] →  → **MF Assist** → an option.

* Default

Option	Description
Off	Do not use the MF Assist function.
Enlarge x5*	<p>The focus area is magnified by 5 times when you rotate the focus ring.</p> 
Enlarge x8	<p>The focus area is magnified by 8 times when you rotate the focus ring.</p> 

DMF (Direct Manual Focus)

You can adjust the focus manually by rotating the focus ring after achieving focus by half-pressing [**Shutter**].

To set the DMF function,

In Shooting mode, press [MENU] →  → **DMF** → an option.

Setting MF & DMF responsiveness

Set the focus ring's response when you use manual focus or the DMF function. If you select **High**, slight rotations of the focus ring will adjust the focus. If you select **Low**, longer rotations of the focus ring will adjust the focus.

To set MF Responsiveness options,

In Shooting mode, press [MENU] →  → **MF Responsiveness** → an option.

AF Release Priority

Set to capture a photo when focus is achieved, or to select accuracy priority or shooting speed priority.

To set AF Release Priority options,

In Shooting mode, press [MENU] →  → **AF Release Priority** → an option.

* Default

Option	Description
Focus*	<p>Capture a photo only when the focus is achieved. You can set the priority either on focus accuracy or shooting speed.</p> <ul style="list-style-type: none"> • Auto*: The camera automatically selects Accuracy priority or Shooting speed priority. • Accuracy priority: Sets accurate focus as the priority. When you select the Continuous High or Burst shooting method, the Accuracy priority setting is applied only on the first shot. • Shooting speed priority: Sets the shooting speed as the priority.
Release	<p>Capture a photo when you press [Shutter] even when focus is not achieved.</p>

Focus Peaking

In the manual focus mode, the color you selected appears on the focused subject to help you focus while rotating the focus ring.

To set Focus Peaking options,

In Shooting mode, press [MENU] →  → **Focus Peaking** → an option.

* Default

Option	Description
Level	Set a sensitivity for detecting the focused subject. (Off, High, Normal*, Low)
Color	Set a color to appear on the focused subject. (White*, Red, Green)



The Focus Peaking function is not available when you select a resolution of 4096X2160 or 3840X2160.



Optical Image Stabilization (OIS)

Use the Optical Image Stabilization (OIS) function to minimize camera shake. OIS may not be available with some lenses.



Camera shake tends to occur in dark locations or when shooting indoors. Under these conditions, the camera uses slower shutter speeds to increase the amount of light it takes in, which can result in a blurry photo. You can prevent this by using the OIS function.

If your lens has an OIS switch, you must set the switch to **ON** to use the OIS function.

To set OIS options,

In Shooting mode, press [MENU] →  → **OIS (Anti-Shake)** → an option.

* Default

Icon	Description
	Off: The OIS function is off.
	Mode 1*: The OIS function is applied only when you full or half press [Shutter].
	Mode 2: The OIS function is on.

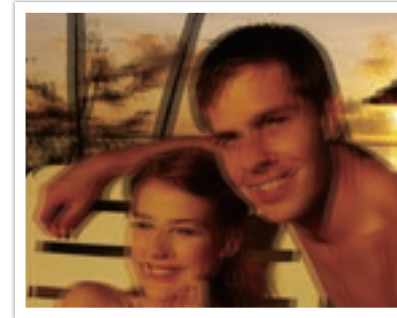

Without OIS correction

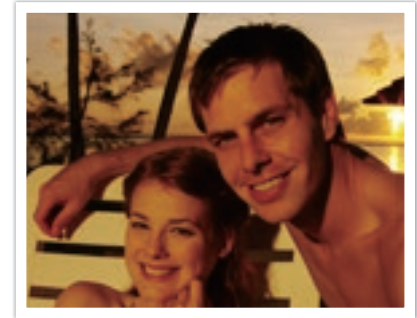

With OIS correction



- OIS may not function properly when:
 - You move your camera to follow a moving subject.
 - There is too much camera shake.
 - The shutter speed is slow (for example, when you select **Night** in **S** mode).
 - The battery is low.
 - You capture a close-up shot.
- If you use the OIS function with a tripod, your images may be blurred by the vibration of the OIS sensor. Deactivate the OIS function when you use a tripod.
- If the camera is hit or dropped, the display will be blurry. If this occurs, turn off the camera, and then turn it on again.
- Use the OIS function only when needed because the function consumes more battery power.
- To set an OIS option on the menu, set the OIS switch on your lens to **ON**.
- This option may not be available with some lenses.

Drive (shooting method)

You can set the shooting method, such as Continuous, Burst, Timer, or Bracketing.

Select **Single** to capture one photo at a time. Select **Continuous Normal**, **Continuous High**, or **Burst** to shoot fast moving subjects. Select **AE Bracket**, **WB Bracket**, **P Wiz Bracket**, or **Depth Bracket** to adjust exposure, White Balance, apply Picture Wizard effects, or capture photos with different depths of field. You can also select **Timer** to capture a photo automatically after a specified time.

To change the shooting method,

In Shooting mode, press [Fn] → an option.



- You can also set the option by pressing [MENU] → [Camera icon] → **Drive** → a shooting method in Shooting mode.
- Available options may differ depending on shooting conditions.

Single

Capture one photo whenever you press [**Shutter**]. Recommended for general conditions.

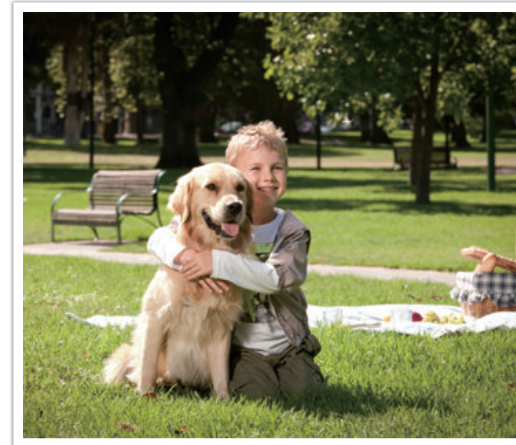

Continuous

Continuously capture photos while you are pressing [**Shutter**]. You can capture up to 4 photos (**Continuous Normal**) or 9 photos (**Continuous High**) per second.



- The noise reduction function is not available when **Continuous High** is selected.
- The Tracking AF function is available with this option.
- You can select up to ISO 25600 when using **Continuous Normal** or up to ISO 6400 when using **Continuous High**.
- When you continuously capture photos, for best results set the shutter speed at 1/250 s or higher. If you set the shooting speed at 9 fps in **Continuous High**, set the shutter speed at 1/500 s or higher.
- Maximum shooting speed is 9 frames per second. It will slow down after approx. JPEG 40 shots, RAW 5 shots. (Based on UHS-I SD Card. May vary depending on the spec of memory card.)

Burst

Consecutively capture up to 10 shots per second (3 seconds), 15 shots per second (2 seconds), or 30 shots per second (1 second) when you press [**Shutter**] once. Recommended for shooting the rapid motion of fast moving subjects such as racing cars.

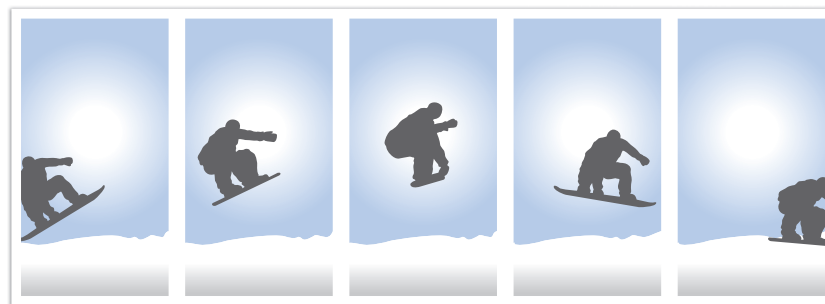

- To set the shooting speed, in Shooting mode, press [**Q**] → **Burst**, and then press [DISP].
- The photo size is set to 7M.
- It may take longer to save a photo.
- You cannot use the flash with this option.
- Shutter speed must be faster than 1/30 second.
- Photos captured with this option may be slightly enlarged when saved.
- You cannot set an ISO option higher than ISO 6400.
- This option cannot be used with the RAW file format. Selecting this option will change the photo quality from RAW to JPEG.

Timer

Capture a photo after a specified time. You can also set the shooting interval, number of shots, and shooting time.

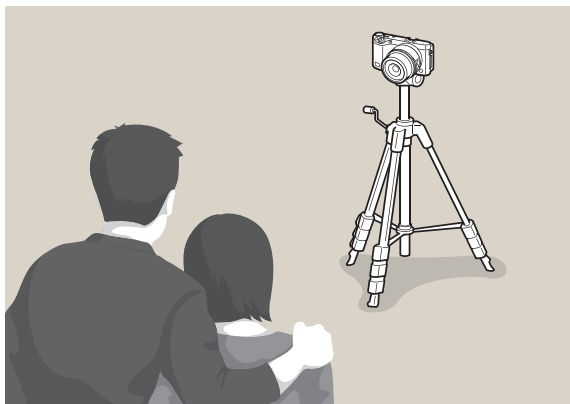

- Press **[Shutter]** to stop capturing.
- To set the timer details, press **[]** → **Timer** → **[DISP]** → set the shooting interval, number of shots, and shooting time.

Auto Exposure Bracketing (AE Bracket)

When you press **[Shutter]**, the camera captures 3 consecutive photos: the original and two more with different exposure settings. Use a tripod to prevent blurry photos as the camera captures three photos continuously. You can adjust the settings in the Bracket Settings menu.



White Balance Bracketing (WB Bracket)

When you press [**Shutter**], the camera captures 3 consecutive photos: the original and two more with different White Balance settings. The original photo is captured when you press [**Shutter**]. The other two are automatically adjusted according to the White Balance you have set. You can adjust the settings in the Bracket Settings menu.



This option cannot be used with the RAW file format. Selecting this option will change the photo quality from RAW to JPEG.

Picture Wizard Bracketing (P Wiz Bracket)

When you press [**Shutter**], the camera captures 3 consecutive photos, each with a different Picture Wizard setting. The camera captures a photo and applies the three Picture Wizard options you have set to the image captured. You can select three different settings in the Bracket Settings menu.



This option cannot be used with the RAW file format. Selecting this option will change the photo quality from RAW to JPEG.

Depth Bracketing

When you press [**Shutter**], the camera captures 3 consecutive photos, each with a different depth of field by adjusting the aperture value. Use a tripod to prevent blurry photos as the camera captures three photos continuously. You can adjust the settings in the Bracket Settings menu.



This feature is available only in Program or Aperture priority mode.

Bracketing settings

You can set up the options for each bracket function.

To set a bracketing option,

In Shooting mode, press [MENU] →  → **Drive** → select a bracketing option, and then press [AF] → set up the options for each bracketing.

* Default

Option	Description
AE Bracket	Set the exposure interval. (-/+ 0.3 EV* , -/+ 0.7 EV , -/+ 1.0 EV , -/+ 1.3 EV , -/+ 1.7 EV , -/+ 2.0 EV , -/+ 2.3 EV , -/+ 2.7 EV , -/+ 3.0 EV)
WB Bracket	Adjust the White Balance interval range of the 3 bracketed photos. (AB -/+1, AB -/+2, AB -/+3*, MG -/+1, MG -/+2, MG -/+3) For example, AB -/+3 adjusts the Amber value plus or minus three steps. MG -/+3 adjusts the Magenta value the same amount.
P Wiz Bracket	Select the 3 Picture Wizard settings the camera will use to capture the 3 bracketed photos.
Depth Bracket	Set the depth interval. Use command dials 1 or 2 to select an option. You can also drag the slider or touch the arrows to select an option. (-/+ 0.3 , -/+ 0.7 , -/+ 1.0* , -/+ 1.3 , -/+ 1.7 , -/+ 2.0 , -/+ 2.3 , -/+ 2.7 , -/+ 3.0)



Interval Capture

Set the shooting interval, the number of shots, and shooting start time. Use this function to capture photos at regular intervals during an event, such as a lunar eclipse or a sunrise.

To capture an interval shot,

In Shooting mode, press [MENU] →  → **Interval Capture** → set a shooting interval, the number of shots, and shooting start time → **Start Interval Capture** → wait for shooting to begin at the time you set. (If you did not set a shooting start time, press [**Shutter**] to capture the photo.)









- To save interval shots as a video, select **Time Lapse** → **On**. The camera records a UHD video up to 60 seconds long at a rate of 10 fps. When using the Time Lapse function, you can set the count to less than 600 shots.
- If you set the interval count to more than 600 shots or there is not enough space on the memory card after the Time Lapse function has been set, the interval count will change automatically to allow you to use the Time Lapse function.
- Touch  to pause while capturing photos.
- Touch  to resume.
- Touch  or press [MENU] to stop capturing.
- Use a shutter release cable with a tripod to minimize camera movement when capturing interval shots.
- Connect the power cable if the shooting interval is long or the number of shots to be taken is high.
- If the shooting interval is set to between one minute and 10 minutes, the camera will enter Display save mode after it starts to capture a photo. If a shooting interval exceeds 10 minutes, the camera will enter Power save mode and turn on and capture a photo automatically at the next interval. Press [**Shutter**] to cancel Power save mode.
- If the battery or memory card is removed while capturing photos, shooting will stop. Before removing the battery or memory card, interval shooting must be paused and the camera must be turned off.

Flash



To capture a realistic photo of a subject, the amount of light should be constant. When the light source varies, you can use a flash and supply a constant amount of light. Select appropriate settings according to a light source and a subject.

To set flash options,

In Shooting mode, press [MENU] →  → **Flash** → an option.

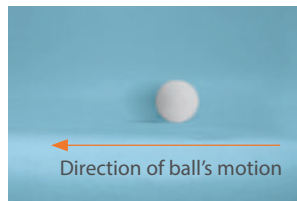
Icon	Description
	Off: The flash is off.
	Smart Flash: The camera automatically adjusts the brightness of the flash according to the amount of light in the surrounding environment.
	Auto: The flash automatically fires in dark locations.
	Auto Red-eye: The flash automatically fires and reduces red-eye.
	Fill-in: The flash fires whenever you capture a photo. (Brightness is automatically adjusted.)
	Fill-in Red: The flash fires whenever you capture a photo and reduces red-eye.
	1st Curtain: The flash fires immediately after the shutter opens. The camera captures a photo of a subject earlier in an action sequence clearly.



Icon	Description
	2nd Curtain: The flash fires just before the shutter closes. The camera captures a photo of a subject later in an action sequence clearly.
	Hi-speed: If the shutter speed is faster than the camera's sync speed (the shortest time taken to open and close the shutter), the flash will fire multiple times at high speed. The flash starts to fire while the shutter opens. This option can be set only when you attach a compatible, optional external flash. (SEF-580A)

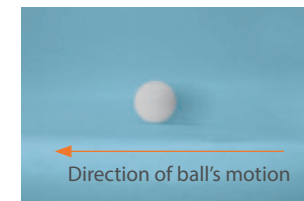

- The available options may differ depending on shooting conditions.
- When you use Red-eye correction, there is an interval between two bursts of the flash. Do not move until the flash fires a second time.
- If you select **Off**, the flash does not fire even when an external flash is attached. If you adjust the flash intensity manually, the flash will fire once without a pre-flash.



Use only Samsung-approved flashes. Using incompatible flashes may damage your camera.

Reducing the red-eye effect

When you capture a photo of a person in the dark using the flash, a red glow may appear in their eyes. To reduce this red-eye effect, select **Auto Red-eye** or **Fill-in Red**.



Without red-eye reduction



With red-eye reduction





When the red-eye reduction function is used, there are two separate flashes. The subject should not move until after the second flash. If the subject is too far from the camera or moves after the first flash fires, red-eye may not be reduced.

Adjusting the flash intensity

When the flash is on, adjust the flash intensity +/-2 levels.

To set the flash intensity,

In Shooting mode, select [MENU] →  → **Flash** → an option → [DISP] → scroll command dial 1 or 2 or press [/AF] to adjust the flash intensity.

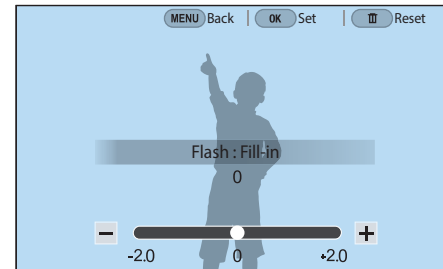



- You can also drag the slider or touch **-/+** to adjust the intensity.
- Adjusting the flash intensity may not be effective when:
 - The subject is too close to the camera.
 - You set a high ISO sensitivity.
 - The exposure value is too big or too small.
 - It is too bright or too dark.
- In some shooting modes, you cannot use this function.
- If you attach an intensity-adjustable external flash to the camera, the intensity settings of the flash will be applied.
- If the subject is too close when you use the flash, some light may be blocked, resulting in a dark photo. Ensure that the subject is within the recommended range, which varies by lens.
- When a lens hood is attached, the light from the flash can be blocked by the hood. Remove the hood to use the flash.

Flash settings

Set the flash mode, exposure value, flash brightness, or multi flash when you attach an external flash to the camera. You can also set wireless sync to control the external flash. The flash settings are supported only when you attach a compatible, optional external flash (SEF-580A).

Setting external flash

To set external flash,

In Shooting mode, press [MENU] →  → **External Flash Settings** → an option.

Option	Description
Flash Mode	<ul style="list-style-type: none"> • A-TTL: In the A-TTL (Advanced Through The Lens) mode, the camera measures the light reflected by the subject through the lens. Then, it calculates the optimum exposure based on the exposure value and shutter speed. • Manual Flash: The flash emits the full amount of light or the flash intensity can be adjusted manually. • Multi Flash: When you press [Shutter], the flash fires multiple times based on the number you have set.
Flash EV	Set the exposure of the flash when the flash mode is A-TTL .
Flash Output	Set the brightness of the flash when the flash mode is Manual Flash .
Multi Flash Settings	Set the count, brightness, or frequency of the flash when the flash mode is Multi Flash .



If data can be exchanged between the camera and the flash, the settings for the external flash can be adjusted on the camera or the flash. Your previous options will be applied.

Setting wireless sync for external flash

Set wireless sync to control internal and external flash units remotely via wireless signals. The remote system consists of a master flash that is mounted on the camera and one or more slave flash units. A slave flash is assigned to one of three groups: A, B, or C.

To set wireless sync,

In Shooting mode, press [MENU] →  → **External Wireless Flash** → an option.

* Default

Option	Description
Use Wireless Flash	Set to use wireless sync. (Off* , On)
Channel	Select channels for wireless sync. There are four remote channels available to allow multiple remote systems to operate at the same time. Master and slave flash units, in the same remote system, must be set to the same channel. (Ch. 1 , Ch. 2 , Ch. 3 , Ch. 4)
Group Flash Mode	Set the flash mode for group A, B, or C. Changes to the flash mode must be made on the master flash. The changes are then applied to slave group A, B, or C, and the slave groups operate as a remote system of the flash mode (TTL or manual) according to the settings for the master flash. <ul style="list-style-type: none"> • A-TTL: Set the exposure of the flash when the flash mode is A-TTL. • Manual Flash: Set the brightness of the flash when the flash mode is Manual Flash. • Off: Do not fire the flash.



- You cannot select **External Flash Settings** when you use the External Wireless Flash function.
- For information about using the wireless sync feature with an external flash, refer to the optional external flash's (SEF-580A) user manual.

Locking the flash intensity

When the flash mode is set to A-TTL, the camera automatically calculates the optimum exposure through pre-flash. If the exposure is not calculated correctly, use the FEL function. The pre-flash fires on the area that you set and the flash intensity is locked.

To lock the flash intensity,

Set the function of [AEL] to **FEL** → focus on the exposure area → press [AEL].

Metering

The metering mode refers to the way in which a camera measures the quantity of light.

The camera measures the amount of light in a scene, and in many of its modes, uses the measurement to adjust various settings. For example, if a subject looks darker than its actual color, the camera captures an overexposed photo of it. If a subject looks lighter than its actual color, the camera captures an underexposed photo of it.

The brightness and overall mood of the photo can also be affected by how the camera measures the amount of light. Select an appropriate setting for the shooting condition.

To set a metering option,

In Shooting mode, press [MENU] →  → **Metering** → an option.

Multi

The Multi mode calculates the amount of light in multiple areas. When light is sufficient or insufficient, the camera adjusts the exposure by averaging the overall brightness of the scene. This mode is suitable for general photos.



Center-weighted

The Center-weighted mode calculates a broader area than the Spot mode does. It sums up the amount of light in the center portion of the shot (60–80 %) and that of the rest of the shot (20–40 %). It is recommended for situations where there is a slight difference in brightness between a subject and its background or where the area around a subject is large compared to the overall composition of the photo.



Spot

The Spot mode calculates the amount of light in the center. When you capture a photo in conditions where there is a strong backlight behind a subject, the camera adjusts the exposure to shoot the subject correctly. For example, when you select the Multi mode in a strong backlight condition, the camera calculates that the overall amount of light is abundant, which results in a darker photo. The Spot mode can prevent this situation as it calculates the amount of light in a designated area.

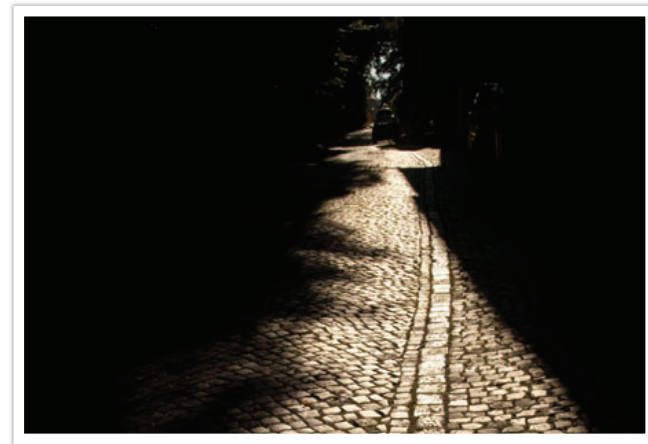

As the photo illustrates, the subject is in a bright area while the background is dark. The Spot mode is recommended for a situation like this where there is a large difference in the exposure values between the subject and the background.

Measuring the exposure value of the focus area

When this function is turned on, the camera automatically sets an optimal exposure by calculating the brightness of the focus area. This function is only available when you select **Spot** metering or **Multi** metering, and **Selection AF**.

To set this function,

In Shooting mode, press [MENU] →  → **Link AE to AF Point** → an option.



Dynamic Range

This function automatically corrects for the loss of bright or dark detail that can occur due to shading differences in the photo.

To set Dynamic Range options,

In Shooting mode, press [MENU] →  → **Dynamic Range** → an option.



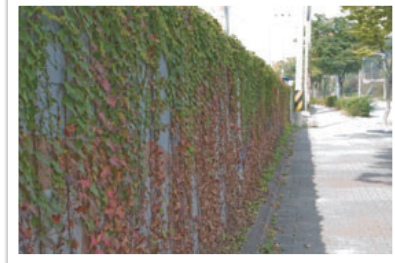

Without Dynamic Range effect



With Dynamic Range effect

* Default

Icon	Description
	Off* : Dynamic Range is off.
	Smart Range+ : Corrects for the loss of bright or dark detail.
	<p>HDR: Capture several photos with different exposures, and then combine them to automatically create a single image.</p> <ul style="list-style-type: none"> To set the exposure adjustment value, press [AF], and then select Low, Medium, or High. You cannot set an ISO option higher than ISO 6400. Dynamic Range options and Picture Wizard options cannot be set at the same time.

Exposure compensation

The camera automatically sets the exposure by measuring the levels of light from the photo's composition and the position of a subject. If the exposure set by the camera is higher or lower than you expected, you can adjust the exposure value manually. The exposure value is adjustable in ± 5 increments. The camera displays the exposure warning in red for each step beyond ± 5 range. When recording a video, the exposure value is adjustable in ± 3 increments.

To adjust the exposure value, hold down [Fn], and then scroll command dial 1. You can also adjust the exposure value by pressing [Fn], and then selecting **EV**.

When you adjust the exposure value in Manual mode, the current shutter speed and aperture value do not change. When you adjust the exposure value by rotating command dial 1 while holding down [Fn] with ISO sensitivity set to Auto, the camera adjusts the exposure value by changing the ISO sensitivity.

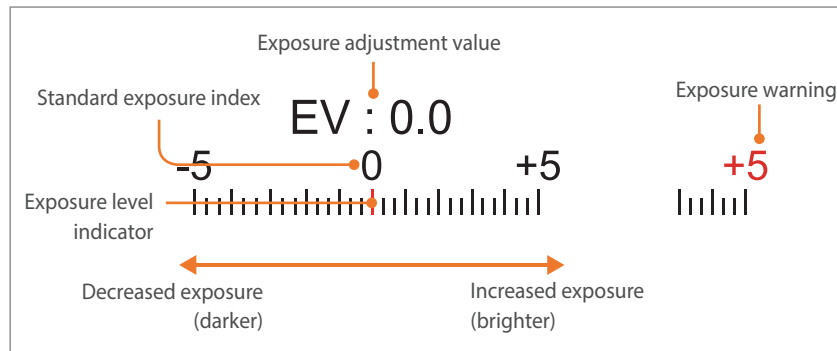

Using Framing Mode

When you adjust the aperture value or shutter speed, the exposure changes, so the display may darken. With this function on, the brightness of the display is constant regardless of the settings, so you can better frame your shot.

To use **Framing Mode**,

In Shooting mode, press [MENU] → [Camera Icon] → **Framing Mode** → an option.

Using the brightness adjustment guide

Adjust the brightness using the selected area as a reference. The brightness of the selected area is displayed as a value to help you to conveniently adjust the brightness.

To adjust the brightness,

In Shooting mode, press [MENU] →  → **Brightness Adjustment Guide** → **On** → locate **+** on the screen in the reference area → press [AEL] → use command dials 1 and 2, or [Q/AF], or drag the slider to adjust the brightness.



- This feature is available only in Program, Aperture Priority, or Shutter Priority mode.
- This feature and the overexposure guide cannot be set at the same time.
- This feature and the Dynamic Range HDR option cannot be set at the same time.
- This feature and the flash options cannot be set at the same time.

Viewing the overexposure guide

View overexposed areas on a photo in Shooting mode before capturing a photo. Setting this feature will cause the overexposed areas of a photo to blink.

To view the overexposure guide,

In Shooting mode, press [MENU] →  → **Overexposure Guide** → an option.

Histogram

Set the histogram on the display on or off.

About histogram

A histogram is a graph that shows the brightness distribution of a photo. A histogram inclined to the left indicates a dark photo. A histogram inclined to the right indicates a bright photo. The height of the graph is related to color information. The graph gets higher if a specific color is more common.

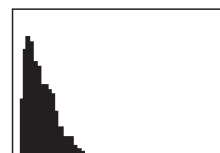

Insufficient exposure

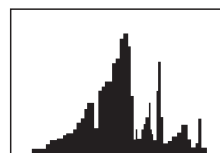

Balanced exposure



Excessive exposure

Exposure/Focus lock

If you cannot achieve an appropriate exposure because of a strong light/dark contrast between the subject and the background, or you want to capture a photo in which the subject is out of the auto focus area, lock the focus or exposure and then capture a photo.

When the exposure lock function is assigned to [AEL] (example)

- 1 Set the focus frame and half-press [**Shutter**] to measure the exposure.



- 2 Press [**AEL**] to lock the exposure.
- 3 Make changes to the composition after the exposure is locked.

- 4 Half-press [**Shutter**] to achieve focus, and then press [**Shutter**] to take a photo.

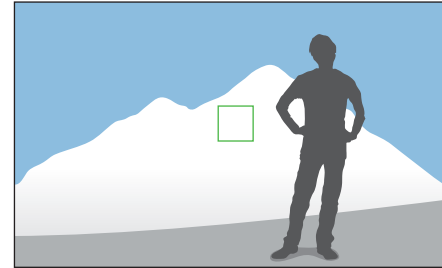

When the focus lock function is assigned to [AEL] (example)

- 1 Set the focus frame and half-press [**Shutter**] to achieve focus.
- 2 Press [**AEL**] to lock the focus.
- 3 Make changes to the composition after the focus is locked.
- 4 Half-press [**Shutter**] to measure the exposure, and then press [**Shutter**] to take a photo.



You can change the function assigned to [AEL] to focus lock, exposure lock, or both. (p. 175)

Exposure/Focus separation

Separate the exposure area and the focus area or merge them again. This feature is available only when Touch AF is set to **Touch AF**.

1 On the screen, touch an area to focus on it.

- The exposure separation icon  will appear on the focus frame.

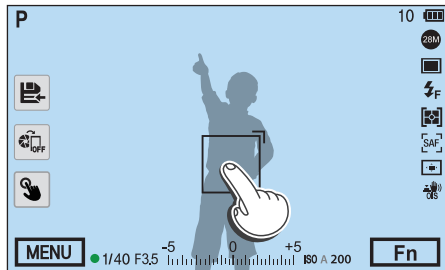

2 Drag  to the exposure area.

- The focus area and the exposure area will be separated.
- Touch and hold each area to lock the focus or exposure setting.
- Drag the areas together to merge the focus area and the exposure area.

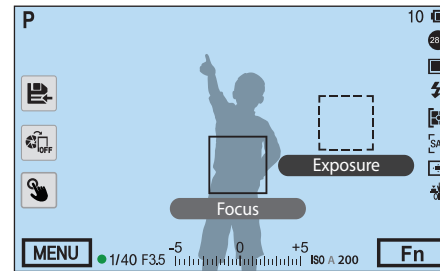

3 Press [**Shutter**] to capture the photo.



- If you press [**AEL**] while its function is set to **AEL Hold**, the exposure/focus will not be separated.
- You can set the Exposure/Focus Separation function On or Off by pressing [MENU] →  → **Exposure/Focus Separation** → **On** or **Off** in Shooting mode.

Video functions

The functions available for video are explained starting below.

Movie size













Set the movie size.

To set movie size options,

In Shooting mode, press [MENU] →  → **Movie Size** → an option.

When Video Out is set to NTSC

* Default

Icon	Size	Recommended for
	4096X2160 (24p)	View on a 4K UHD TV.
	3840X2160 (30p)	View on a 4K UHD TV.
	1920X1080 (60p)	View on a Full HDTV. (Videos recorded with this option may not play on some HDTVs or smart phones that do not support 60p.)
	1920X1080 (30p)	View on a Full HDTV.
	1920X1080 (24p)	View on a Full HDTV.
	1920X1080 (15p)	View on a Full HDTV. (Available only with some Smart Filter options.)
	1280X720 (120p)	View on an HDTV. (Videos recorded with this option may not play on some HDTVs or smart phones that do not support 120p.)
	1280X720 (60p)	View on an HDTV.
	1280X720 (30p)	View on an HDTV.
	640X480 (60p)	View on a TV.
	640X480 (30p)	View on a TV.
	640X480 (MJPEG)	View on a TV.

When Video Out is set to PAL

* Default

Icon	Size	Recommended for
	4096X2160 (24p)	View on a 4K UHD TV.
	3840X2160 (25p)	View on a 4K UHD TV.
	1920X1080 (50p)	View on a Full HDTV. (Videos recorded with this option may not play on some HDTVs or smart phones that do not support 50p.)
	1920X1080 (25p)	View on a Full HDTV.
	1920X1080 (24p)	View on a Full HDTV.
	1920X1080 (12.5p)	View on a Full HDTV. (Available only with some Smart Filter options.)
	1280X720 (100p)	View on an HDTV. (Videos recorded with this option may not play on some HDTVs or smart phones that do not support 100p.)
	1280X720 (50p)	View on an HDTV.
	1280X720 (25p)	View on an HDTV.
	640X480 (50p)	View on a TV.
	640X480 (25p)	View on a TV.
	640X480 (MJPEG)	View on a TV.



If you select a video size of 4096X2160 or 3840X2160 and connect the camera to an HDMI-supported TV via an HDMI cable, the video size is automatically set to 1920X1080 (30p).

Movie quality

Set the Movie quality.

To set movie quality options,

In Shooting mode, press [MENU] → → **Movie Quality** → an option.

* Default

Icon	Extension	Description
	HEVC, MP4	Normal: Record videos in normal quality.
	HEVC, MP4	HQ*: Record videos in high quality.
	HEVC, MP4	Pro: Record videos in ultra high quality. Available only when the movie size is set to 1920X1080 or higher.



is a format provided for editing. Video in may not play smoothly depending on your computer's specifications. We recommend you connect the camera to a UHD TV with an HDMI cable to ensure the video plays smoothly.

Bit rates for movie sizes

File format	Movie Size		Bit rate (Pro) Mbit/s	Bit rate (HQ) Mbit/s	Bit rate (Normal) Mbit/s	Frame rate	Sensor output
MP4	4K	4096X2160	70	40	32	24p	24p
	UHD	3840X2160	70	40	32	30p	29.97p
			70	40	32	25p	25.00p
	FHD	1920X1080	70	37	19	60p	59.94p
			70	37	19	50p	50.00p
			60	25	13	30p	29.97p
			60	25	13	25p	25.00p
	HD	1280X720	60	25	13	24p	24.00p
			-	30	15	120p	119.88p
			-	30	15	100p	100p
			-	19	9	60p	59.94p
			-	19	9	50p	50.00p
			-	13	6	30p	29.97p
	VGA	640X480	-	13	6	25p	25.00p
			-	7	3	60p	59.94p
			-	7	3	50p	50.00p
			-	4	2	30p	29.97p
	AVI	VGA	640X480	-	4	2	25p
-				13.8	11.1	30p	29.97p
-				11.5	9.2	25p	25.00p
-				11.5	9.2	25p	25.00p

* The bit rates above may vary depending on the shooting conditions.

* The bit rates above are based on HEVC codec.







Fast/Slow Movie

Set the playing speed of a video.

To set playing speed options,

In Shooting mode, press [MENU] →  → **Fast/Slow Movie** → an option.

* Default

Icon	Description
	x0.25 : Record a video to view it at 1/4 normal speed during playback. Available only with 1280X720 (30p/25p), 640X480 (30p/25p).
	x0.5 : Record a video to view it at 1/2 normal speed during playback. Available only with 1920X1080 (30p/25p), 1280X720 (60p/50p/30p/25p), 640X480 (60p/50p/30p/25p).
	x1* : Record a video to view it at normal speed during playback.
	x5 : Record a video to view it at 5X normal speed during playback.
	x10 : Record a video to view it at 10X normal speed during playback.
	x20 : Record a video to view it at 20X normal speed during playback.



- If you select an option other than **x1**, the sound recording function and the Distortion Correct function will not be supported.
- The available options may differ depending on shooting conditions.

AF Responsiveness

Set the delay time for the focus to automatically change during video recording. When a new subject enters the frame, the camera shifts the focus slowly if the responsiveness is set to low. If the responsiveness is set to high, the camera shifts the focus quickly.

To adjust the AF Responsiveness,

In Shooting mode, press [MENU] →  → **AF Responsiveness** → an option.



- This function is available only when **Fast/Slow Movie** is set to **x1**.
- This function is not available with the following lenses:
 - SAMSUNG 16mm F2.4
 - SAMSUNG 20mm F2.8
 - SAMSUNG 30mm F2
 - SAMSUNG 60mm F2.8 Macro ED OIS SSA
 - SAMSUNG 85mm F1.4 ED SSA
 - SAMSUNG 20-50mm F3.5-5.6 ED II

AF Shift Speed

Set how fast the auto focus function operates during video recording. A fast shift speed is useful for capturing action shots, such as sporting events. A slow shift speed enables smooth changes of focus depending on the subject.

To adjust the AF Shift Speed,

In Shooting mode, press [MENU] →  → **AF Shift Speed** → an option.



- This function is available only when **Fast/Slow Movie** is set to **x1**.
- This function is not available with the following lenses:
 - SAMSUNG 16mm F2.4
 - SAMSUNG 20mm F2.8
 - SAMSUNG 30mm F2
 - SAMSUNG 60mm F2.8 Macro ED OIS SSA
 - SAMSUNG 85mm F1.4 ED SSA
 - SAMSUNG 20-50mm F3.5-5.6 ED II





Fader

Add dramatic effects to your videos. Set the fade in option to gradually fade the video in at the start of a scene. Set the fade out option to gradually fade the video out at the end of a scene.

To set fader options,

In Shooting mode, press [MENU] →  → **Fader** → an option.

* Default

Icon	Description
	Off* : The fader function is off.
	In : Scene gradually fades in.
	Out : Scene gradually fades out.
	In-out : The fader function is applied at the start and end of the scene.



When you use the fader function, it may take longer to save a file.

Voice

Sometimes, a muted video is more appealing than one with sound. Turn Voice off to record a muted video.

To set voice options,

In Shooting mode, press [MENU] →  → **Voice** → an option.

Wind Cut

When you record videos in noisy environments, unintended sounds can be recorded in videos. In particular, severe wind noise can prevent you from enjoying your videos. Use the Wind Cut function to remove some surrounding noise in addition to wind noise.



To reduce wind sound,

In Shooting mode, press [MENU] →  → **Wind Cut** → an option.

Mic Level

Set a mic level appropriate for the shooting conditions.

To set the mic level,

In Shooting mode, press [MENU] →  → **Mic Level** → scroll command dials 1 and 2 or press [/AF] to adjust the mic level → touch **Set**.

Smart Range+

Correct for the loss of bright or dark detail.

To set Smart Range+ options,

In Shooting mode, press [MENU] →  → **Smart Range+** → an option.



Chapter 3

Playback/Editing

Learn about how to play back and edit photos and videos.

Searching and managing files

Learn how to view photo and video thumbnails and how to protect or delete files.



If you perform no operations for a while, information and icons on the screen disappear. When you press a button or touch the screen, they will reappear.

Viewing photos

1 Press **[▶]**.

- The most recent file you captured will be displayed.



2 Scroll command dial 2 or press **[⏪/AF]** to scroll through files.

- You can also drag the image left or right to move to another file.



You will not be able to edit or play back files that were captured with other cameras if the file format sizes or codecs are not supported by your NX500. Use a computer or another device to edit or play back these files.

Viewing image thumbnails

To search for photos and videos, change to the thumbnail view. The thumbnail view displays multiple images at a time so that you can easily look for items you want to find. You can also classify and display files by category, such as date or file type.

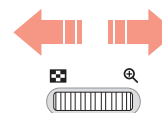

Scroll command dial 1 to the left to select the thumbnail view mode.

(Scroll command dial 1 to the right to return to the previous mode.)

Viewing files by category

- 1 In the thumbnail view, press [MENU] →  → **Filter** → a category.
 - You can also touch the current category name to open the option list.

Option	Description	* Default
All*	View files normally.	
Date	View files by the date they were saved.	
Type	View files by the file type.	

- 2 Select a list to open it.
- 3 Select a file to view it.
- 4 Touch  to return to the previous view.



Viewing continuous and burst shots

View continuous and burst shots from a photo bundle. Select a photo bundle to play back all photos in the bundle automatically. If you delete a photo bundle, all photos in the photo bundle will be deleted. The photos in a photo bundle are saved as an individual photo file on the memory card; a separate folder is not created. You can choose to view continuous shots as a bundle or view them separately.



- 1 In Playback mode, scroll command dial 2 or press $\left[\frac{\text{OK}}{\text{MENU}} \right]$ to move to a desired photo bundle.
 - You can also drag the image left or right to move to a desired folder.
 - The camera will automatically play back photos in the photo bundle.
 - Press $[\text{MENU}] \rightarrow \left[\frac{\text{OK}}{\text{MENU}} \right] \rightarrow \text{View Continuous Shots} \rightarrow \text{Unfold}$ to view continuous shots separately.



- 2 Scroll command dial 1 to the right to open the photo bundle.
 - You can also touch the photo bundle on the screen or press $\left[\frac{\text{OK}}{\text{MENU}} \right]$ to open the photo bundle.
- 3 Scroll command dial 2 or press $\left[\frac{\text{OK}}{\text{MENU}} \right]$ to scroll through files.
 - You can also drag the image left or right to move to another file.
- 4 Scroll command dial 1 to the left or press $\left[\frac{\text{OK}}{\text{MENU}} \right]$ to return to Playback mode.
 - You can also touch $\left[\frac{\text{OK}}{\text{MENU}} \right]$ to return to Playback mode.

Protecting files

Protect your files from accidental deletion.

- 1 In Playback mode, press [MENU] →  → **Protect** → **Multiple Protect**.
- 2 Scroll command dial 2 or press [/AF] to move to a file, and then select the file by pressing [].
- 3 Press [AEL].



- You cannot delete or rotate a protected file.
- You can directly protect a file in Playback mode by selecting a file, and then pressing [AEL]. To unprotect the file, press [AEL] again.
- Press [AEL] while a photo bundle is selected to protect all continuous shots in the bundle.

Lock/Unlock all files

Lock or unlock all files.

- 1 In Playback mode, press [MENU] →  → **Protect** → **Protect All**.
- 2 Select an option.

Option	Description
Cancel	Return to the previous menu.
Unlock	Unlock all files.
Lock	Lock all files.

Deleting files

Delete files in Playback mode and secure more space on your memory card. Protected files can be deleted once the protection is removed.

Deleting a single file

You can select a single file and delete it.

- 1 In Playback mode, select a file, and then press [🗑️].
- 2 When the pop-up message appears, select **Yes**.

Deleting multiple files

You can select multiple files and delete them.

- 1 In Playback mode, press [MENU] → [▶] → **Delete** → **Multiple Delete**.
 - In thumbnail view, press [MENU] → [🗑️] → **Select Item**.
 - Alternatively, in thumbnail view, press [🗑️], and then select files to delete.

- 2 Scroll command dial 2 or press [🔍/AF] to move to a file, and then select the file by pressing [OK].
 - Press [OK] again to cancel your selection.
- 3 Press [🗑️].
- 4 When the pop-up message appears, select **Yes**.

Deleting all files

You can delete all files on the memory card at once.

- 1 In Playback mode, press [MENU].
- 2 Select [▶] → **Delete** → **Delete All**.
- 3 When the pop-up message appears, select **Yes**.

Viewing photos

Enlarging a photo

You can enlarge photos when viewing them in Playback mode. You can also use the Trim function to extract the portion of the image displayed on the screen and save it as a new file.

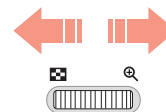
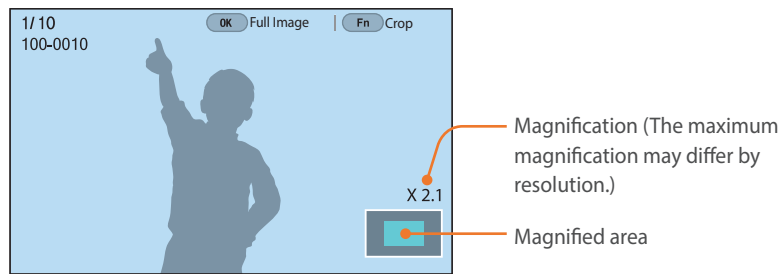

Scroll command dial 1 to the right to enlarge a photo.
(Scroll command dial 1 to the left to reduce a photo.)

To	Do this
Move magnified area	Press [DISP/ISO/AF].
Crop the enlarged image	Press [Fn]. (saved as a new file)
Return to the original image	Press [OK].



- You can also pinch your fingers together or spread them apart on the screen to reduce or enlarge a photo. You can also double-tap an area to enlarge it quickly.
- You can scroll through files by scrolling command dial 2, even when a photo is enlarged.

Viewing a slide show

You can view photos in a slide show and apply various effects.

- 1 In Playback mode, press [MENU].
- 2 Select  → **Slide Show Options**.
- 3 Select a slide show effect option.
 - Skip to step 4 to start a slide show with no effects.



* Default

Option	Description
Play Mode	Set to play a slide show once or repeatedly. (One Play* , Repeat)
Interval	Set the interval between photos. (1 sec* , 3 sec , 5 sec , 10 sec)
Effect	<ul style="list-style-type: none"> • Set a scene change effect between photos. • Select Off to cancel effects.

4 Press [MENU].

5 Select **Start Slide Show**.

6 View the slide show.

- Press [>] to pause.
- Press [>] again to resume.
- Press [MENU] to stop the slide show and return to Playback mode.

Viewing the overexposure guide

Make the overexposed areas in a photo blink.

To view the overexposure guide,

In Playback mode, press [MENU] →  → **Overexposure Guide** → an option.

Viewing interval shots

View photos that are captured with the Interval Capture function.

To view interval shots,

In Playback mode, press [MENU] →  → **Play Interval Shots**.

Sorting files

Sort files by most recent or by oldest.

To set a sorting option,

In Playback mode, press [MENU] →  → **Sort by** → an option.

Auto rotating

With Auto Rotate on, the camera automatically rotates photos you have captured vertically so they fit the screen horizontally.

To set auto rotate options,

In Playback mode, press [MENU] →  → **Auto Rotate** → an option.

Converting to JPEG

Convert RAW files to JPG files.

To convert files,

In Playback mode, press [MENU] →  → **Convert to JPG**.

Playing videos

In Playback mode, you can play a video, capture an image from a video, or crop a video to save as another file.

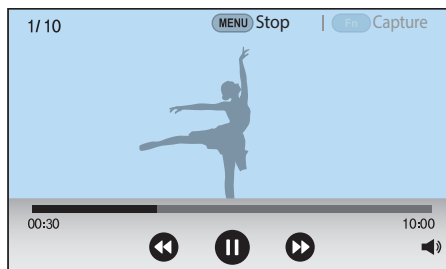

Icon	Description
	View previous file/Scan backward. (Each time you touch the icon while playing a video, you change the scan speed in this order: 2X, 4X, 8X.)
	Pause or resume playback.
	View next file/Scan forward. (Each time you touch the icon while playing a video, you change the scan speed in this order: 2X, 4X, 8X.)
	Adjust the volume or mute the sound.

Scanning backward or forward

To scan backward or forward through a video file while it is playing, use one of the following methods.

- Touch . Each time you touch the icon, you change the scan speed in this order: 2X, 4X, 8X.
- Press /AF]. Each time you press the button, you change the scan speed in this order: 2X, 4X, 8X.
- Scroll command dials 1 or 2 to the left or right. Each time you scroll command dials 1 or 2, you change the scan speed in this order: 2X, 4X, 8X.
- Drag the handles that appear on the progress bar to the left or right. You can change the playback position in the video.



You can pause a video and scroll command dial 2 to scan back or forward in single frame increments.

Adjusting the brightness of a video

Adjust the brightness of a video while playing it.

To adjust the brightness of a video,

Touch the left half of the display → drag upward or downward.

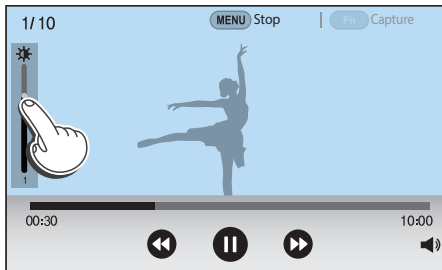



Adjusting the volume of a video

Adjust the volume of a video while playing it.



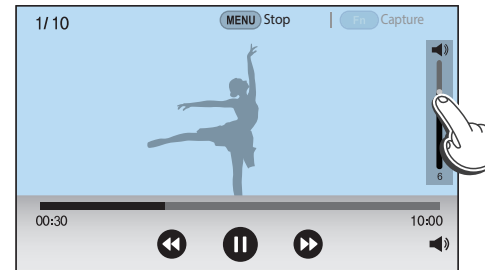

To adjust the volume of a video,

Touch the right half of the display → drag upward or downward.



- You can also touch  and drag the slider on the volume control bar upward or downward.
- You can also press [DISP/ISO] to adjust the volume of a video.

Trimming a video during playback

- 1 In Playback mode, scroll to a video, and then press [MENU].
- 2 Select **Trim Movie**.
- 3 Press [OK] or touch  to start playing the video.
- 4 Press [OK] or touch  at the point where you want the trimming to begin.
- 5 Press [Fn] or touch **Start Point**.
- 6 Press [OK] or touch  to resume playing the video.
- 7 Press [OK] or touch  at the point where you want the trimming to end.
- 8 Press [Fn] or touch **End Point**.
- 9 Press [Fn] or touch **Trim** to trim a video.
 - You can adjust the scene to be cropped by dragging the handles that appear on the progress bar.

10 When the pop-up message appears, select **Yes**.



- You cannot trim a video recorded in 3D mode.
- The original video should be at least 10 seconds long.
- The camera will save the edited video as a new file and leave the original video intact.

Capturing an image during playback

- 1 While viewing a video, press [OK] or touch  at the point where you want to capture an image.
- 2 Press [Fn] or touch **Capture**.



- You cannot capture an image from a video recorded in 3D mode.
- The resolution of the captured image will be the same as the original video.
- The captured image is saved as a new file.

Editing photos

Perform photo editing tasks, such as resizing or rotating. Edited photos are saved as new files under different file names. Photos captured in some modes cannot be edited with the Image Edit function.





To edit images,

In Playback mode, scroll to a photo, and then press [MENU] →  → **Edit Image** → an option.



- Some images cannot be edited with the Edit Image function. In this case, use the supplied image editing software.
- The camera will save edited photos as new files.
- Edited photos may be converted to a lower resolution.
- You cannot edit photos while viewing continuous shots from a photo bundle. Open the photo bundle and select a photo to edit it.

Cropping a photo

- 1 Touch  → .
- 2 Drag the sides of the box to adjust the size of the crop area.
- 3 Drag the box to move the location of the crop area.
- 4 Press [] or touch **Done**.
- 5 Touch  to save.

Rotating a photo

1 Touch  → .

2 Touch an option.

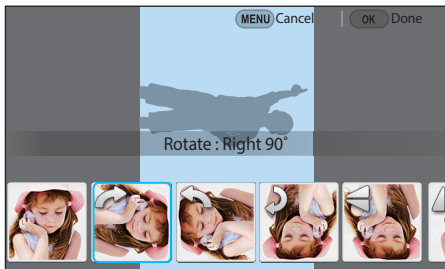

3 Press [] or touch **Done**.

4 Touch  to save.



- You can also rotate a photo in Playback mode by pressing [MENU], and then selecting  → **Rotate** → a desired option.
- The camera will overwrite the original file.

Resizing photos

Change the size of a photo and save it as a new file.

1 Touch  → .

2 Touch an option.

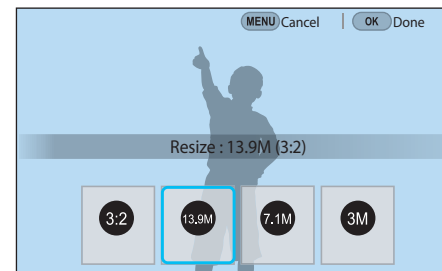

3 Press [] or touch **Done**.

4 Touch  to save.



Available resize options differ depending on the original size of the photo.









Adjusting your photos

You can correct captured photos by adjusting the brightness, contrast, or color.

1 Touch .

2 Touch an adjusting option.

- If you selected  (Auto adjustment), skip to step 4.

Icon	Description
	Original (Reset to the original image.)
	Auto adjustment
	Brightness
	Contrast
	Saturation
	RGB adjustment
	Color Temperature
	Exposure
	Hue

3 Scroll command dial 1 or 2 or press [/AF] to adjust the option.

- You can also drag the slider or touch +/- to adjust the option.

4 Press [] or touch **Done**.

5 Touch  to save.

Retouching faces

1 Touch  → .

2 Scroll command dial 1 or 2 or press [/AF] to adjust the option.

- You can also drag the slider or touch +/- to adjust the option.
- As the number increases, the skin tone becomes brighter and smoother.

3 Press [] or touch **Done**.

- To cancel correction, touch .

4 Touch  to save.

Applying Smart Filter effects

Apply special effects to your photos.

1 Touch , and then touch an option.

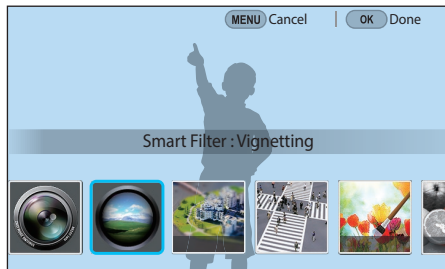

Option	Description
Original	No effect
Vignetting	Apply the retro-looking colors, high contrast, and strong vignette effect of Lomo cameras.
Miniature (H)	Apply a tilt-shift effect to make the subject appear in miniature. The top and bottom of the photo will be blurred.
Miniature (V)	Apply a tilt-shift effect to make the subject appear in miniature. The left and right of the photo will be blurred.

Option	Description
Watercolor	Apply a watercolor painting effect.
Red	Desaturate all colors but red.
Green	Desaturate all colors but green.
Blue	Desaturate all colors but blue.
Yellow	Desaturate all colors but yellow.

2 Press  or touch **Done**.

3 Touch  to save.



Chapter 4

Connecting & Transferring

Learn how to share photos or videos and use various features.

Connecting to a smart phone

Using the NFC Feature

Place a smart phone's NFC antenna near the camera's NFC tag to connect the camera to the smart phone. You can also transfer files to an NFC-enabled device in Playback mode.



- This feature is supported by NFC-enabled smart phones running the Android OS. We recommend that you use the latest version. This feature is not available for iOS devices.
- You should install Samsung Camera Manager on your phone or device before using this feature. Download and install Samsung Camera Manager Inst. from the Google Play Store to install Samsung Camera Manager. Samsung Camera Manager is supported by Android OS 4.2.2 or higher.
- To read an NFC tag, place the NFC-enabled device near the camera's NFC tag for more than 2 seconds.
- You can set the size for transferred photos by pressing [MENU], and then selecting  → **MobileLink/NFC Image Size** → an option.
- Do not modify the NFC tag in any way.

Using NFC features in Shooting mode

In Shooting mode, connect a camera and a smart phone by placing the NFC antenna of one device near the NFC tag of the other. Press [] or turn on Samsung Camera Manager on the smart phone, and then launch MobileLink, Remote Viewfinder, Quick Transfer, or Pro Suggest Market. (p. 144, 146, 149)

Using NFC features in Playback mode (Photo Beam)

In Playback mode, the camera transfers the current files to the smart phone automatically when you place the two devices close to each other while they are connected via Bluetooth.

- To transfer multiple files, select files from the thumbnail view, and then read a tag from an NFC-enabled device.

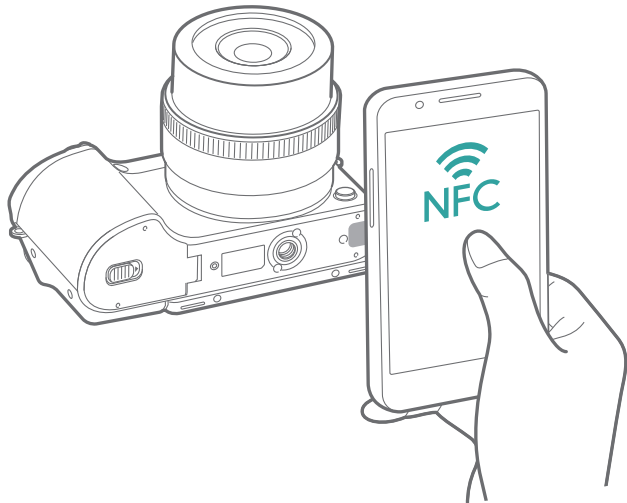

Using the GPS Geo Tagging Feature

To save GPS information when you take a photo using the camera, connect the camera and smart phone via Bluetooth. Then, activate the GPS feature on the smart phone.

Sending files to a smart phone

You can use the MobileLink feature to easily send photos to your smart phone.



- The MobileLink feature is supported by smart phones or tablets running the Android OS or iOS. (Some features may not be supported by some models.) Before using this feature, update the device's firmware to the latest version. If the firmware version is not the most recent, this function may not perform properly.
- You should install Samsung Camera Manager on your phone or device before using this feature. Download and install Samsung Camera Manager Inst. from the Google Play Store or the Apple App Store to install Samsung Camera Manager. Samsung Camera Manager is supported by Android OS 4.2.2, iOS 6.1 or higher.
- If there are no files in the camera's memory, you cannot use this feature.
- You can view up to 1,000 recent files and send up to 1,000 files at a time.
- When using this feature on an iOS device, the device may lose its Wi-Fi connection.
- You cannot send MJPEG files.
- You cannot send videos to an iOS device.
- RAW files are sent after being converted to JPEG format.
- Video playback is not available on smart phones that do not support H.265 codecs.
- You can set the size for transferred photos by pressing [MENU], and then selecting → **MobileLink/NFC Image Size** → an option.
- The screen turns off if you perform no operations on the camera for 30 seconds.
- You can also touch in Playback mode, and then select .

1 In Shooting mode, press [].

- You can also press and hold [] to launch the MobileLink feature directly.

2 Touch .

- If the pop-up message that prompts you to download the application appears, select **Next**.
- If you use a Wi-Fi manual connection to connect the camera and a smart phone, you can enable the Wi-Fi Privacy lock. (p. 183)
- If you use a Wi-Fi manual connection to connect the camera and a smart phone, the Bluetooth feature is not available.

3 On the smart phone, turn on Samsung Camera Manager.

- To start the application automatically on an NFC-enabled smart phone, turn on the function and place the smart phone near the NFC tag (p. 32) on the camera. Verify that the smart phone is connected to your camera, and then skip to step 6.

- 4 Select the camera from the list on the smart phone.
 - The smart phone can connect to only one camera at a time.
 - If the Wi-Fi Privacy lock is enabled and Wi-Fi is connected, enter the PIN displayed on the camera into the smart phone.
- 5 On the camera, allow the smart phone to connect to your camera or confirm the registration request.
 - If the smart phone has been connected to your camera before, it is connected automatically.
 - If the pop-up message that prompts you to set the auto time setting appears, select **Yes** to sync the camera's date and time to the smart phone's. (p. 183)
- 6 Select files to transfer.
- 7 On the smart phone, touch .
 - The camera will send the files to the smart phone.



Controlling the camera remotely with a smart phone

Use the Remote Viewfinder feature on your smart phone to control your camera and remotely capture a photo or record video.



- The Remote Viewfinder feature is supported by smart phones or tablets running the Android OS or iOS. (Some features may not be supported by some models.) Before using this feature, update the device's firmware to the latest version. If the firmware version is not the most recent, this function may not perform properly.
- You should install Samsung Camera Manager on your phone or device before using this feature. Download and install Samsung Camera Manager Inst. from the Google Play Store or the Apple App Store to install Samsung Camera Manager. Samsung Camera Manager is supported by Android OS 4.2.2, iOS 6.1 or higher.
- This function is not available when you attach a 3D lens in 3D mode.

1 In Shooting mode, press [.

2 Touch .

- If the pop-up message that prompts you to download the application appears, select **Next**.
- If you use a Wi-Fi manual connection to connect the camera and a smart phone, you can enable the Wi-Fi Privacy lock. (p. 183)
- If you use a Wi-Fi manual connection to connect the camera and a smart phone, the Bluetooth feature is not available.





3 On the smart phone, turn on Samsung Camera Manager.

- To start the application automatically on an NFC-enabled smart phone, turn on the function and place the smart phone near the NFC tag (p. 32) on the camera. Verify that the smart phone is connected to your camera, and then skip to step 6.

4 Select the camera from the list on the smart phone.

- The smart phone can connect to only one camera at a time.
- If the Wi-Fi Privacy lock is enabled and Wi-Fi is connected, enter the PIN displayed on the camera into the smart phone.

- 5 On the camera, allow the smart phone to connect to your camera or confirm the registration request.
 - If the smart phone has been connected to your camera before, it is connected automatically.
 - If the pop-up message that prompts you to set the auto time setting appears, select **Yes** to sync the camera's date and time to the smart phone's. (p. 183)
- 6 On the smart phone, select  to open the smart panel.
- 7 On the smart phone, set the shooting options.
 - While using this feature, some buttons are not available on your camera.
 - The zoom button and the shutter button on your smart phone will not function when using this feature.
 - Some shooting options are not supported.
 - Shooting options that you have set will remain on the camera after the connection with the smart phone has ended.

- 8 Touch  to return to the shooting screen.
- 9 On the smart phone, touch and hold  to focus, and then release it to capture the photo.
 - Touch  to record a video and touch  to stop a video.
 - Touch  to view the captured photo and send it to the smart phone.
 - If the GPS feature is activated on the smart phone, the GPS information will be saved with the captured photo.



- When you use this feature, the ideal distance between the camera and the smart phone may vary, depending on your surroundings.
- The smart phone must be within 23 ft (7 m) of the camera to use this feature.
- It will take some time to capture the photo after you release  on the smart phone.
- The Remote Viewfinder function will deactivate when:
 - You answer an incoming call on the iOS devices.
 - Either the camera or the smart phone turns off.
 - The device loses a Bluetooth or Wi-Fi connection.
 - The Bluetooth or Wi-Fi connection is poor or unstable.
 - You perform no operations for approximately 3 minutes while connected.

Using a smart phone as a remote shutter release







Use the Bluetooth Shutter function in Samsung Camera Manager on the smart phone to use the smart phone as a remote shutter for the camera.



- This feature is supported by smart phones running the Android OS. We recommend that you use the latest version. This feature is not available for iOS devices.
- You should install Samsung Camera Manager on your phone or device before using this feature. Download and install Samsung Camera Manager Inst. from the Google Play Store to install Samsung Camera Manager. Samsung Camera Manager is supported by Android OS 4.2.2 or higher.

- 1 Connect the camera and a smart phone via Bluetooth.
- 2 On the smart phone, turn on Samsung Camera Manager.
- 3 Select **Bluetooth Shutter**.

4 On the smart phone, touch  to capture the photo.

- Select **Press** and touch  to capture a single photo each time you touch .
- Select **Press & Hold** and touch  to allow [**Shutter**] to remain pressed. Press  again to release [**Shutter**]. When capturing continuous shots or using the Bulb function, select **Press & Hold** and touch  to capture photos for the desired time.
- Touch  to start recording a video and touch  to stop a video.





- The ideal distance for a Bluetooth connection between devices may vary, depending on your surroundings and your smart phone.
- The smart phone must be within 23 ft (7 m) of the camera to use this feature.
- The Bluetooth Shutter function will deactivate when:
 - Either the camera or the smart phone turns off.
 - The device loses a Bluetooth connection.
 - The Bluetooth connection is poor or unstable.

Saving files to a smart phone automatically

When you capture a photo with your camera, the photo is saved to a smart phone automatically using the Quick Transfer feature.



- The Quick Transfer feature is supported by smart phones or tablets running the Android OS. (Some features may not be supported by some models.) Before using this feature, update the device's firmware to the latest version. If the firmware version is not the most recent, this function may not perform properly.
- You should install Samsung Camera Manager on your phone or device before using this feature. Download and install Samsung Camera Manager Inst. from the Google Play Store to install Samsung Camera Manager. Samsung Camera Manager is supported by Android OS 4.2.2 or higher.
- If you set this function, the setting is maintained even when you change the Shooting mode.
- This feature may not be supported in some modes or may not be available with some shooting options.
- The Quick Transfer feature is only supported via a Bluetooth connection.
- You cannot use the Quick Transfer feature if the camera is connected to a smart phone that does not support Bluetooth via a Wi-Fi connection.
- If a smart phone that does not support Bluetooth is registered to the camera, you must delete it and register a smart phone that supports Bluetooth.

- 1 In Shooting mode, touch .
 - You can also press [, and then select .
 - If the pop-up message that prompts you to download the application appears, select **Next**.
- 2 On the smart phone, turn on Samsung Camera Manager.
 - To start the application automatically on an NFC-enabled smart phone, turn on the function and place the smart phone near the NFC tag (p. 32) on the camera. Verify that the smart phone is connected to your camera, and then skip to step 5.
- 3 Select the camera from the list on the smart phone.
 - The smart phone can connect to only one camera at a time.

4 On the camera, confirm the smart phone's registration request.

- If the smart phone has been connected to your camera before, it is connected automatically.
- The Quick Transfer icon on the camera's screen will be changed to an icon that shows the connection status (📶).
- If the pop-up message that prompts you to set the auto time setting appears, select **Yes** to sync the camera's date and time to the smart phone's. (p. 183)

5 Capture a photo.

- The captured photo is saved to the camera in its original size and a preview image is transferred to the smart phone. To import the original image from the camera to your smart phone, select the preview image on your smart phone.
- If you captured continuous photos, the first captured photo is transferred to the smart phone.
- If the GPS feature is activated on the smart phone, the GPS information will be saved with the captured photo.



Downloading custom modes via a smart phone

You can download various shooting settings (film) to a smart phone and share them with the camera using the Pro Suggest Market feature.



- Pro Suggest Market is supported by smart phones or tablets running the Android OS or iOS. (Some features may not be supported by some models.) Before using this feature, update the device's firmware to the latest version. If the firmware version is not the most recent, this function may not perform properly.
- If you use an iOS device, Pro Suggest Market is supported on the device using 3G or LTE data.
- You should install Samsung Camera Manager on your phone or device before using this feature. Download and install Samsung Camera Manager Inst. from the Google Play Store or the Apple App Store to install Samsung Camera Manager. Samsung Camera Manager is supported by Android OS 4.2.2, iOS 6.1 or higher.
- You cannot delete the four films preloaded in the camera.
- The custom mode saved on the camera is automatically shared to a smart phone when the camera and a smart phone are connected.
- Some of the shooting settings (film) may not be supported on the camera.

1 In Shooting mode, press [].

2 Touch .

- If the pop-up message that prompts you to download the application appears, select **Next**.
- If you use a Wi-Fi manual connection to connect the camera and a smart phone, you can enable the Wi-Fi Privacy lock. (p. 183)
- If you use a Wi-Fi manual connection to connect the camera and a smart phone, the Bluetooth feature is not available.

3 On the smart phone, turn on Samsung Camera Manager.

- To start the application automatically on an NFC-enabled smart phone, turn on the function and place the smart phone near the NFC tag (p. 32) on the camera. Verify that the smart phone is connected to your camera, and then skip to step 6.

- 4 Select the camera from the list on the smart phone.
 - The smart phone can connect to only one camera at a time.
 - If the Wi-Fi Privacy lock is enabled and Wi-Fi is connected, enter the PIN displayed on the camera to the smart phone.
- 5 On the camera, allow the smart phone to connect to your camera or confirm the registration request.
 - If the smart phone has been connected to your camera before, it is connected automatically.
 - If the pop-up message that prompts you to set the auto time setting appears, select **Yes** to sync the camera's date and time to the smart phone's. (p. 183)
- 6 Select **Pro Suggest Market**.
- 7 Download a desired film.
 - You must create your Samsung Account to download films from Pro Suggest Market.
 - Downloaded films are saved to the camera as custom modes.



Sending photos via email

Connect to a network and send stored photos on the camera via email.

Connecting to a WLAN

Learn to connect via an access point (AP) when you are in a range of a WLAN. You can also configure network settings.





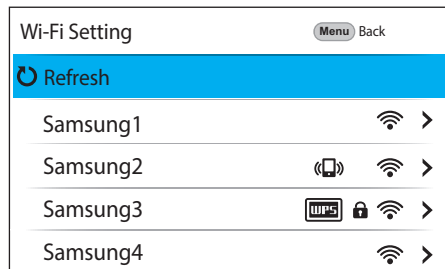

1 In Playback mode, touch .



- The camera automatically searches for available AP devices.
- If a pop-up message about data collection regulations appears, read and agree to it.

2 Select an AP.



- Select **Refresh** to refresh the list of connectable APs.
- Select **Add a wireless network** to add an AP manually. When you add an AP manually, the AP name must be in English.

Icon	Description
	Ad hoc AP
	Secured AP
	WPS AP
	Signal strength
	Press [AF] or touch  to open network setting options.

- When you select a secured AP, a pop-up window appears. Enter the required passwords to connect to the WLAN. For information about entering text, refer to “Entering text”. (p. 156)
- If you select an unsecured AP, the camera will connect to the WLAN.
- If you select a WPS profile supported AP, select  → **WPS PIN connection**, and then enter a PIN on the AP device. You can also connect to a WPS profile supported AP by selecting  → **WPS button connection** on the camera, and then pushing the **WPS** button on the AP device.

Setting network options

- 1 In the Wi-Fi Setting screen, move to an AP, and then press [AF] or touch ➤.
- 2 Select each option, and then enter the required information.

Option	Description
Network Password	Enter the network password.
IP Setting	Set the IP address automatically or manually.

Manually setting the IP address

- 1 In the Wi-Fi Setting screen, move to an AP, and then press [AF] or touch ➤.
- 2 Select **IP Setting** → **Manual**.
- 3 Select each option, and then enter the required information.

Option	Description
IP	Enter the static IP address.
Subnet Mask	Enter the subnet mask.
Gateway	Enter the gateway.
DNS Server	Enter the DNS address.





Network connection tips

- You must insert a memory card to use the Wi-Fi features.
- The quality of the network connection will be determined by the AP.
- The further the distance between your camera and the AP, the longer it will take to connect to the network.
- If a nearby device is using the same radio frequency signal as your camera, it may interrupt your connection.
- If your AP name is not in English, the camera may not be able to locate the device or the name may appear incorrectly.
- For network settings or a password, contact your network administrator or network service provider.
- Depending on the encryption type, the number of digits in the password may differ.
- A WLAN connection may not be possible in all surroundings.
- The camera may display a WLAN enabled printer on the AP List. You cannot connect to a network via a printer.
- You cannot connect your camera to a network and a TV simultaneously.
- Connecting to a network may incur additional charges. Costs will vary based on the conditions in your contract.
- If you cannot connect to a WLAN, try another AP from the available AP list.
- Available network connections may differ by country.
- The WLAN feature of your camera must comply with radio transmission laws in your region. To ensure compliance, use the WLAN feature only in the country where you purchased the camera.
- The process for adjusting network settings may differ, depending on network conditions.
- Do not access a network that you are not authorized to use.
- Before you connect to a network, ensure your battery is fully charged.
- Files that you transfer to another device may not be supported by the device. In this case, use a computer to play back the files.
- Network speed may differ depending on the Wi-Fi specification supported by the AP.

Entering text

Learn how to enter text. The icons in the table let you move the cursor, change the case, etc. Touch a key to enter it.











Icon	Description
	Change case.
	Switch between Symbol/Number mode and the normal mode.
	<ul style="list-style-type: none"> • Touch to enter a space. • Change the input language by dragging it to the left or the right.
	Save the displayed text.
	Delete the last letter.



- You can use only the English alphabet in some modes, regardless of the display language.
- The number of characters you can enter varies depending on the situation.
- The screen may differ depending on the input mode.
- Touch and hold a key to enter the character at the upper right corner of the key.

Sending photos via email

You can send photos stored on the camera via email. For information about entering text, refer to “Entering text”. (p. 156)



- 1 In Playback mode, touch 
 - In thumbnail view, select  → a file, and then press [Fn]. You can select up to 5 files. The total size must be 7 MB or less.
- 2 Connect to a WLAN. (p. 153)
- 3 Select the **Sender** box, enter your email address, and then touch 
 - If you have previously saved your information, it will be inserted automatically. (p. 158)
 - To use an address from the list of previous senders, select  → an address.
- 4 Select the **Receiver** box, enter an email address, and then touch 
 - To use an address from the list of previous recipients, select  → an address.
 - Select  to add additional recipients. You can input up to 30 recipients.
 - Select  to delete an address from the list.
- 5 Select **Next**.
- 6 Select the comment box, enter your comments, and then touch .
- 7 Select **Send**.
 - The camera will send the email.
 - If an email fails to send, a message prompting you to send it again appears.



- Even if a photo appears to have transferred successfully, errors with the recipient's email account may cause the photo to be rejected or recognized as spam.
- You may not be able to send an email if no network connection is available or if your email account settings are incorrect.
- You cannot send an email if the combined file sizes exceed the 7 MB. If the selected photo has a resolution higher than 2M, it will be automatically resized to a lower resolution.
- If you cannot send an email because of firewall or user authentication settings, contact your network administrator or network service provider.
- If there are no files in the camera's memory, you cannot use this feature.

Storing a sender's information

In the email menu, you can change settings for storing a sender's information. For information about entering text, refer to "Entering text". (p. 156)

- 1 In Playback mode, touch .
- The camera will automatically attempt to connect to a WLAN via the most recently connected AP device.
- If the camera has not previously been connected to a WLAN, it will search for available AP devices. (p. 153)
- 2 Press [Fn].
- 3 Select **Sender Setting**.
- 4 Select the **Name** box, enter your name, and then touch .

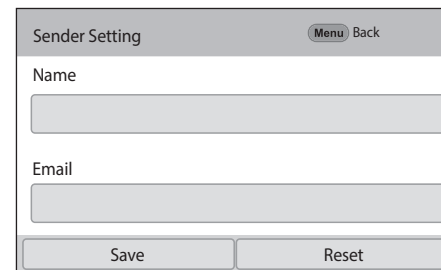

Sender Setting Menu Back

Name

Email

Save Reset

5 Select the **Email** box, enter your email address, and then touch .

6 Select **Save** to save your changes.
• To delete your information, select **Reset**.

Setting an email password

In the email menu, you can set the email password. For information about entering text, refer to "Entering text". (p. 156)

1 In Playback mode, touch .

- The camera will automatically attempt to connect to a WLAN via the most recently connected AP device.
- If the camera has not previously been connected to a WLAN, it will search for available AP devices. (p. 153)

2 Press [Fn].

3 Select **Setting Password** → **On**.

- To deactivate the password, select **Off**.

4 When the pop-up appears, select **OK**.

5 Enter a 4-digit password.

6 Enter the password again.

7 When the pop-up appears, select **OK**.



If you lose your password, you can reset it by selecting **Reset** on the password setting screen. When you reset the information, the previously saved user's setting information and email address will be deleted.

Changing the email password

In the email menu, you can change the email password. For information about entering text, refer to “Entering text”. (p. 156)

- 1 In Playback mode, touch .
 - The camera will automatically attempt to connect to a WLAN via the most recently connected AP device.
 - If the camera has not previously been connected to a WLAN, it will search for available AP devices. (p. 153)
- 2 Press [Fn].
- 3 Select **Change Password**.
- 4 Enter your current 4-digit password.
- 5 Enter a new 4-digit password.
- 6 Enter the new password again.
- 7 When the pop-up appears, select **OK**.



Viewing photos or videos on a TV

Use the Wi-Fi feature or USB cable to play back files from the camera on a TV. To use the Wi-Fi feature and connect the camera wirelessly, the TV must support home networking functions.

Connecting wirelessly

1 In Playback mode, touch .



2 Select  or .

- If the guide message appears, select **OK**.
- The camera will automatically attempt to connect to a WLAN via the most recently connected AP device.
- If the camera has not previously been connected to a WLAN, it will search for available AP devices. (p. 153)
- If you select , a list of files that can be shared with the TV is displayed on the camera. Wait until other devices detect your camera.

3 Connect your TV to a network, and then activate the corresponding feature.

- Refer to the TV's user manual for more information.

4 Connect the camera to the TV.

- If you select , choose a TV to connect to from the list on the camera.
- If you select , enable the TV, and then choose your camera from the list on the TV to connect to it.

5 Browse the shared photos or videos.

- For information about searching for the camera and browsing the photos or videos on your TV, refer to the TV's user manual.
- Videos may not play smoothly depending on the type of your TV or the network condition.

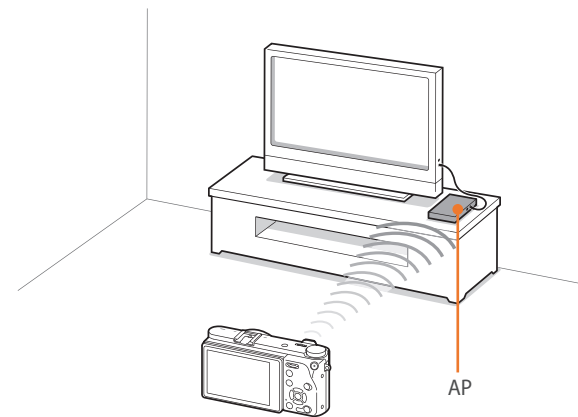

▲ The camera is connected to a TV via a wireless network.



- You can share up to 1,000 recent files.
- On the TV, you can view only photos or videos captured with your camera.
- The range of the wireless connection between your camera and a TV may vary depending on the specifications of the AP.
- If the camera is connected to two TVs, playback may be slower.
- Photos or videos will be shared in their original sizes.
- You can only use this feature with a TV that supports home networking features.
- Shared photos or videos will not be stored on the TV, but they can be stored in the camera to meet the TV's specifications.
- Transferring photos or videos to the TV may take some time depending on the network connection, the number of files to be shared, or the sizes of the files.
- If you power off the camera abnormally while viewing photos or videos on a TV (for example, by removing the battery), the TV considers the camera to still be connected.
- The order of photos or videos on the camera may be different than on the TV.
- Depending on the number and sizes of photos or videos you want to share, it may take some time to load your files and complete the initial set-up process.
- While viewing photos or videos on the TV, continuously using the TV's remote or performing additional operations on the TV may prevent this feature from working properly.

- If you reorder or sort files on the camera while viewing them on a TV, you must repeat the initial set-up process to update the list of files on the TV.
- If there are no files in the camera's memory, you cannot use this feature.
- We recommend you use a network cable to connect your TV to your AP. This will minimize any video 'stuttering' you may experience when streaming content.
- If a nearby device is using the same radio frequency as your camera, the video may stutter when streaming content. We recommend you try other channels on the AP. For more information about changing the AP channel, contact the AP device manufacturer.
- To view files on your TV, enable multicast mode on your AP.
- 1920X1080 (60p) videos can be played only on Full HDTVs or UHD TVs capable of playback at 60p.
- You can view 3D files only on 3D-compatible TVs or monitors.
- Video playback may not be available on devices that do not support HEVC codecs.
- UHD video playback may not work properly on some TVs.

Connecting via cable

Play back photos or videos by connecting your camera to an HDMI-supported TV using an optional HDMI cable.

Viewing files on a TV

- 1 In Shooting or Playback mode, press [MENU] →  → **HDMI Output** → an option. (p. 182)
- 2 Turn off your camera and TV.
- 3 Connect your camera to your TV with an HDMI cable.

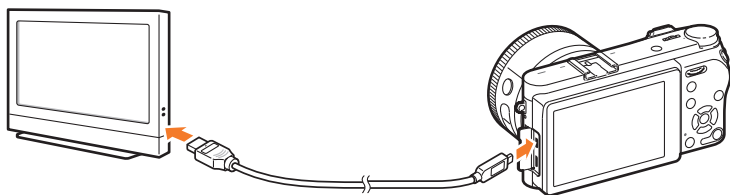

- 4 Turn on your TV and select the HDMI source.
- 5 Turn on the camera.

6 View photos or play videos using the camera buttons.



- If your TV supports Anynet+(CEC), you can connect the camera to the TV with an HDMI cable using the Anynet+(CEC) method.
- The Anynet+(CEC) functions allow you to control connected devices using the TV remote control.
- If the TV supports Anynet+(CEC), the TV turns on automatically when used in conjunction with the camera. This feature may not be available on some TVs.
- You can capture photos and videos when the camera is connected to a TV, but some functions will be limited. Shooting functions are supported only when **HDMI Output** is set to **1920 X 1080p** or **Auto** on the camera and the TV's HDMI output option is set to 1920 X 1080p.
- If you select a video size of 4096X2160 or 3840X2160 and connect the camera to an HDMI-supported TV via an HDMI cable, the video size is automatically set to 1920X1080 (30p).
- When connected to a TV, some of the camera's playback functions may not be available.
- The length of time required to connect the camera and a TV may vary depending on the memory card being used. As the main feature of a memory card is to increase the transfer speed, it is not necessarily true to say that a memory card with a faster transfer speed is also fast in using the HDMI function.
- 1920X1080 (60p) videos can be played only on Full HDTVs or UHD TVs capable of playback at 60p.
- To view 3D photos on a TV that does not support the 3D function, press [ISO] to switch to Anaglyph mode and wear anaglyph glasses.
- You can also play back or capture photos or videos when you connect the camera to an HDMI-enabled monitor. Connections and their capabilities may vary depending on the monitor. Refer to the monitor's manual for more details.
- UHD video playback may not work properly on some TVs.

Viewing files on a 3D TV

You can view photos or videos captured in 3D mode on a 3D TV.

- 1 In Shooting or Playback mode, press [MENU] → ⚙ → **HDMI Output** → an option. (p. 182)
- 2 Turn off your camera and 3D TV.
- 3 Connect your camera to your 3D TV with the optional HDMI cable.
- 4 Turn on your 3D TV, and then select the HDMI video source.
- 5 Turn on your camera.

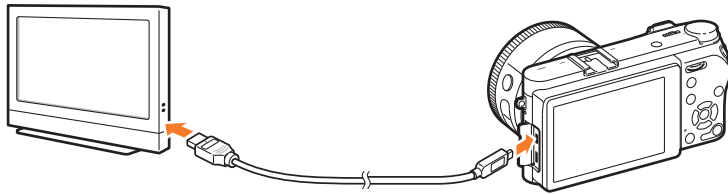

- 6 Move to a 3D file, and then press [ISO] to switch to 3D mode.
 - Press [ISO] again to switch to 2D Mode.
- 7 Turn on your TV's 3D function.
 - Refer to your TV's user manual for more details.
- 8 View 3D photos or play 3D videos using the camera buttons.



- You cannot view an MPO file in 3D on TVs that do not support the file format.
- Use proper 3D glasses when you view an MPO file or a 3D video file on a 3D TV.



Do not view the 3D photos or videos captured by your camera on a 3D TV or 3D monitor for an extended period of time. It may cause unpleasant symptoms, such as eyestrain, fatigue, nausea, and more.

Connecting to a computer

Using Auto Backup for photos or videos

You can send photos or videos that you captured with the camera to a PC wirelessly.



Installing the program for Auto Backup on your PC

- 1 Connect the camera to the PC with the USB cable.
- 2 Turn on the i-Launcher program, and then select **PC Auto Backup**.
 - The Auto Backup program is installed on the PC. Follow the on-screen instructions to complete the installation.
- 3 Remove the USB cable.



Before installing the program, ensure that the PC is connected to a network.

Using the Auto Backup feature

- 1 In Playback mode, select a file, and then touch  → .
 - In thumbnail view, you cannot use the Auto Backup feature.
 - If the pop-up message that prompts you to download the application appears, select **Next**.
 - The camera will automatically attempt to connect to a WLAN via the most recently connected AP device.
 - If the camera has not previously been connected to a WLAN, it will search for available AP devices. (p. 153)
- 2 Select a backup PC.

3 Select **OK**.

- To cancel sending, select **Cancel**.
- You cannot select individual files to backup. This function backs up only new files on the camera.
- The backup's progress will be shown on the PC monitor.
- When the transfer is completed, the camera will turn off automatically in approximately 30 seconds. Select **Cancel** to return to the previous screen and prevent the camera from turning off automatically.
- To turn off your PC automatically after the transfer is complete, select **Shut down PC after backup**.
- To change the backup PC, select **Change PC**.



- When you connect the camera to the WLAN, select the AP that is connected to the PC.
- The camera will search for available access points even if you are connecting to the same access point again.
- If you turn off the camera or remove the battery while sending files, the file transfer will be interrupted.
- While you are using this feature, the shutter control is disabled on your camera.
- You can connect only one camera to the PC at a time for sending files.
- The backup may be canceled due to network conditions.
- If there are no files in the camera's memory, you cannot use this feature.
- You must turn off Windows Firewall and any other firewalls before using this feature.
- You can send up to 1,000 recent files.
- On the PC software, the server name must be entered in the Latin alphabet and can contain no more than 48 characters.

Connecting the camera as a removable disk

Transfer files on a memory card to your computer by connecting the camera to the PC.

Transferring files to your Windows OS computer

You can connect the camera to your computer as a removable disk. Open the removable disk and transfer files to your computer.

1 Turn off the camera.

2 Connect the camera to your computer with the USB cable.

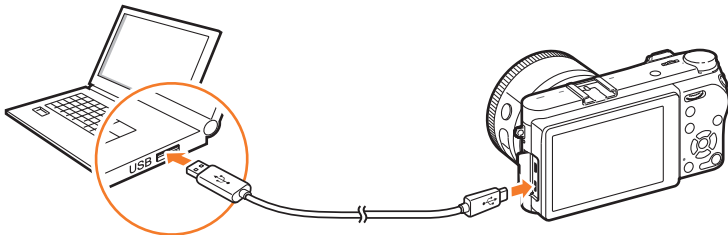

- You must plug the small end of the USB cable into your camera. If the cable is reversed, it may damage your files. The manufacturer is not responsible for any loss of data.
- If you try to plug the USB cable into the HDMI port, the camera may not work properly.

3 Turn on the camera.

- The computer recognizes the camera automatically.

4 On your computer, select **My Computer** → **Removable Disk** → **DCIM** → **100PHOTO** or **101_0101**.



5 Select the files you want, and then drag or save them to your computer.



If the **Folder Type** is set to **Date**, the folder name appears as "XXX_MMDD". For example, if you capture a photo on January 1, the folder name will be "101_0101".

Disconnecting the camera (for Windows 7)

When the camera is connected to the computer as a removable disk, follow the instructions below to disconnect the camera. With Windows 8 and Windows 8.1, the methods for disconnecting the camera are similar.

- 1 Ensure that no data is being transferred between the camera and the computer.
 - If the status lamp on your camera is blinking, it means the data transfer is in progress. Please wait until the status lamp stops blinking.
- 2 Click  on the tool bar at the bottom right of your computer screen.

- 3 Click the pop-up message.
- 4 Click the message box indicating safely removed.
- 5 Remove the USB cable.

Transferring files to your Mac OS

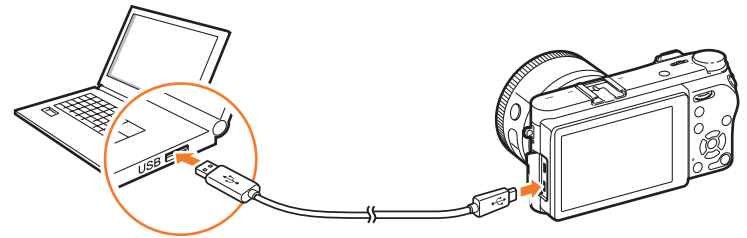

Mac OS 10.7 or later is supported.

- 1 Turn off the camera.
- 2 Connect the camera to your computer with the USB cable.



- You must plug the small end of the USB cable into your camera. If the cable is reversed, it may damage your files. The manufacturer is not responsible for any loss of data.
- If you try to plug the USB cable into the HDMI port, the camera may not work properly.

- 3 Turn on the camera.
 - The computer recognizes the camera automatically and displays a removable disk icon.
- 4 On your computer, open the removable disk.
- 5 Select the files you want, and then drag or save them to your computer.



Chapter 5

Camera settings menu

Learn about the user settings and general settings menu.
You can adjust the settings to better suit your needs and preferences.

User settings

You can set the user environment with these settings.

To set user options,

In Shooting mode, press [MENU] →  → an option.



Available items and their order may differ depending on shooting conditions.

Manage Custom Mode

Create your own shooting modes by adjusting options and saving them. Open saved custom modes or delete them. (p. 67)

RAW Compression

Set the type of compression for RAW files.

* Default

Option	Description
Lossless Compression*	RAW files are compressed without data loss.
Normal Compression	RAW files are compressed with negligible effect on image quality.

Noise Reduction

Use Noise Reduction to reduce the visual noise in photos.

* Default

Option	Description
High ISO NR	This function reduces noise that may occur when you set a high ISO sensitivity. (Off, High, Normal* , Low)
Long Term NR	This function reduces noise when you set the camera for a long exposure. (Off, On*)



If **Long Term NR** is off, image noise may increase when you capture a photo using the Bulb function. When using the Bulb function, we recommend that you set the **Long Term NR** to **On**.

Color Space

The color space option allows you to select methods for representing colors. Digital imaging devices such as digital cameras, monitors, and printers have their own color ranges, referred to as color spaces.

Option	Description
sRGB*	sRGB (Standard RGB) is an international specification that defines the color space created by the IEC (International Electrotechnical Commission). It is widely used for creating colors on PC monitors and is also the standard color space for Exif. For regular images and images that will be published on the Internet, we recommend using sRGB.
Adobe RGB	Adobe RGB is used for commercial printing and has a larger color range than sRGB. Its wider range of colors helps you easily edit photos on a computer. Note that individual programs are generally compatible with a limited number of color spaces.

* Default

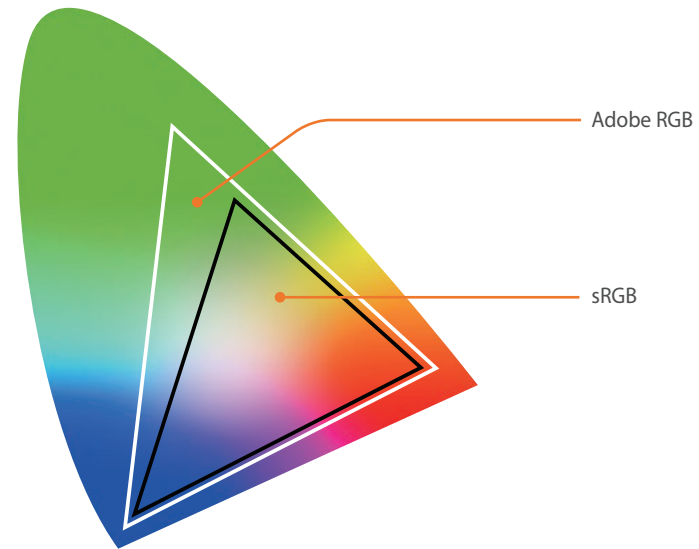

When the color space is set to Adobe RGB, photos will be saved as "_SAMXXXX.JPG".

Distortion Correct

You can correct distortion that can be caused by lenses. This function may not be available with some lenses.

User Display

You can add or remove shooting information from the display.

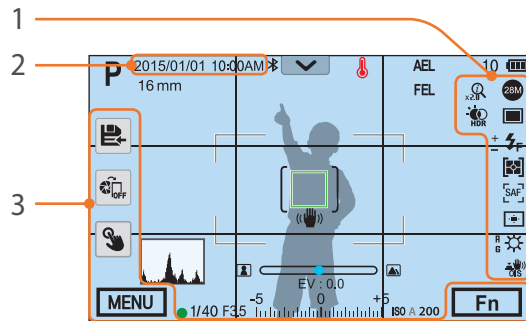

No.	Description
1	Icons Set to display icons on the right in Shooting mode.
2	Date and Time Set to display the date and time.
3	Button Set to display touch icons on the left and the bottom in Shooting mode.

Grid Line

Select a guide to help you compose a scene.

* Default

Option	Description
Off*	Disable grid lines.
4 X 4	Set a 4 X 4 grid.
3 X 3	Set a 3 X 3 grid.
Cross	Set the grid lines as cross hairs.
Diagonal	Set the grid lines to cross diagonally.
Action Safe Area	Display grid lines for the current aspect ratio of a video. This is useful when recording a video to fit on another device's screen or when editing a video.
4:3 Safe Area	Display grid lines for a standard TV aspect ratio (4:3). This is useful when recording a video to fit on another device's screen or when editing a video.
2.35:1 Safe Area	Display grid lines for the cinemascope ratio (2.35:1). This is useful when recording a video to fit on another device's screen or when editing a video.



Grid lines are displayed even while the camera is recording a video.

Center Marker

Set to display a cross-shaped center marker in the center of the screen. Use the center marker to set the vertical and horizontal levels. You can set the size of the center marker or apply effects to it.

Option	Description
Display	Set to turn the center marker on or off. (Off* , On)
Size	Set the size of the center marker. (Large , Normal*)
Transparency	Set to apply a transparency effect to the center marker. (Off* , On)

* Default



The center marker is displayed even while the camera is recording a video.

Key Mapping

You can change the function assigned to the Custom button, the AEL button, the EV button, or command dials 1 and 2.

Custom

Set the Custom button's function.

Option	Description
Optical Preview	Execute the Depth of Field Preview function for the current aperture value. (p. 24)
One Touch WB	Execute the Custom White Balance function.
One Touch RAW +	Save a file in the RAW+JPEG format. To save a file in JPEG format, press the button again.
One Touch HDR	Enable or disable the HDR Dynamic Range option.
Movie STBY*	Switch to Video recording standby mode.

* Default

AEL

Set the function for the AEL button. You can change the function assigned to the button to focus lock, exposure lock, or other shooting functions. The AEL and AFL functions save the exposure value or focus area respectively when you press [AEL]. The function executed by half-pressing [Shutter] varies according to the function assigned to [AEL].

* Default

Option	Description
AEL*	Perform the auto exposure lock function. (Half-pressing [Shutter] executes the auto focus lock function.)
AEL Hold	Keep the auto exposure lock function on after shooting. (The exposure remains locked even after you capture a photo.)
AFL	Perform the auto focus lock function. (Half-pressing [Shutter] executes the auto exposure lock function.)
AFL Hold	Keep the auto focus lock function on after shooting. (The focus remains locked even after you capture a photo.)
AEL + AFL	Perform the auto exposure and focus lock functions together.
AEL+AFL Hold	Keep the auto exposure and focus lock functions on together after shooting. (The exposure and focus remain locked even after you capture a photo.)
FEL	Perform the flash intensity lock function. (p. 110)

* Default

Option	Description
FEL Hold	Keep the flash intensity lock function on after shooting. (The intensity remains locked even after you capture a photo.) (p. 110)
AF Mode	Select a focusing method.
AF Area	Select an auto focus area.
White Balance	Set a White Balance option (light source) that affects the color of a photo.
ISO	Set the sensitivity of the camera to light.
Metering	Select the way in which camera measures the quantity of light.
Touch Operation	Set to enable touch operation in Shooting mode.
Dynamic Range	Select an option to correct brightness differences caused by shadows in the photo.
Minimum Shutter Speed	Set the slowest shutter speed the camera is allowed to use.
Auto ISO Range	Set the maximum ISO value the camera will use to set each EV step when you set the ISO to Auto.
Smart Filter	Apply special effects to a photo.
Picture Wizard	Apply effects to a photo depending on the theme.
Drive	Set Continuous, Burst, Timer, or Bracket shooting options.

* Default

Option	Description
Flash	Set flash options according to the shooting conditions.
intelli-Zoom	Zoom in on a subject with less degradation of photo quality than the Digital zoom.
MF Assist	Set the assist function that helps you focus the camera more easily when you rotate the focus ring manually.
Grid Line	Select a guide to help you compose a scene.

EV

Set the function for the EV button.

* Default

Option	Description
EV*	Adjust the exposure value.
AF Mode	Select a focusing method.
AF Area	Select an auto focus area.
White Balance	Set a White Balance option (light source) that affects the color of a photo.
ISO	Set the sensitivity of the camera to light.
Metering	Select the way in which camera measures the quantity of light.

* Default

Option	Description
Touch Operation	Set to enable touch operation in Shooting mode.
Dynamic Range	Select an option to correct brightness differences caused by shadows in the photo.
Minimum Shutter Speed	Set the slowest shutter speed the camera is allowed to use.
Auto ISO Range	Set the maximum ISO value the camera will use to set each EV step when you set the ISO to Auto.
Smart Filter	Apply special effects to a photo.
Picture Wizard	Apply effects to a photo depending on the theme.
Drive	Set Continuous, Burst, Timer, or Bracket shooting options.
Flash	Set flash options according to the shooting conditions.
intelli-Zoom	Zoom in on a subject with less degradation of photo quality than the Digital zoom.
MF Assist	Set the assist function that helps you focus the camera more easily when you rotate the focus ring manually.
Grid Line	Select a guide to help you compose a scene.

Command Dial

Assign the functions that are adjusted when command dials 1 or 2 are rotated.

Mode	Adjustable functions (command dial 1/command dial 2)
Program	Program Shift/Program Shift* Program Shift/EV Program Shift/ISO EV/Program Shift ISO/Program Shift
Aperture Priority	Aperture/Aperture* Aperture/EV Aperture/ISO EV/Aperture ISO/Aperture
Shutter Priority	Shutter Speed/Shutter Speed* Shutter Speed/EV Shutter Speed/ISO EV/Shutter Speed ISO/Shutter Speed
Manual	Shutter Speed/Aperture* Aperture/Shutter Speed

* Default

iFn Setting

Adjust the iFn settings for an i-Function lens.

Option	Description
iFn Standard	Adjust the shutter speed, aperture value, and other options on the lens by pressing [i-Function] or select options that can be adjusted when you press [i-Function] on an i-Function lens.
iFn Plus	On an i-Function lens, press [i-Function] and a button on the camera at the same time to assign a function to that button. <ul style="list-style-type: none"> • AEL: Select the option that will be adjusted when you press [i-Function] and [AEL] together. • EV: Select the option that will be adjusted when you press [i-Function] and [EV] together.

Lens Button Speed Settings

Set the zoom speed for the Power Zoom lens' buttons at either fast, medium, or slow. At fast speed, zoom noise increases and can be recorded in videos. This function is available only when you attach the Power Zoom lens.

Touch Operation

Set to enable touch operation in Shooting mode.

* Default

Option	Description
Off	Disable touch operations in Shooting mode. (You can use touch operations in other situations.)
On*	Enable touch operations in Shooting mode.

Auto Self Shot

Set to enter Self Shot mode automatically when you flip the display upward. In Self Shot mode, the timer (2 seconds), face detection, and beauty face options are automatically activated.

AF Lamp

When shooting in dark places, turn the AF lamp on to improve the operation of the auto focus. The Auto Focus functions more accurately in dark places when the AF lamp is on. The AF lamp emits light in irregular vertical patterns.

E-Shutter

* Default

Option	Description
Off*	Set to use the mechanical shutter.
On	Set to use the electronic shutter curtain first and the mechanical curtain second.



- This feature is available only when you attach a Samsung lens using a Samsung NX mount.
- We recommend that you use the electronic shutter to minimize camera shake when using a telephoto lens or taking a close-up photo.
- When you use a large diameter lens and a fast shutter speed, a “bokeh” effect (an aesthetic blur in out-of-focus areas) can occur. The effect can be affected by the subject and the shooting conditions. To make the bokeh effect appear correctly, set the **E-Shutter to Off**.
- When you change the E-Shutter settings, the first curtain of the shutter is adjusted and you will hear a noise as the shutter adjusts. This is normal when preparing the camera to operate the E-Shutter.
- This feature is not available when you attach the external flash (SEF-580A).

MobileLink/NFC Image Size

Set the size of photos to transfer to a smart phone using the MobileLink or NFC function.

* Default



Option	Description
Resize to 2M or lower	If a photo's size is larger than 3M, the camera will transfer it after resizing it to 2M or lower.
Original*	The photo will be transferred in its original size.

Setting

Learn to configure your camera's settings.



To set Setting options,

In Shooting or Playback mode, press [MENU] → ⚙ → an option.

Item	Description
	* Default
Sound	<ul style="list-style-type: none"> • System Volume: Set the sound volume or turn all sound off entirely. (Off, Low, Medium*, High)
	 Even if the system volume is turned off, the camera emits the sound while playing a video.
	<ul style="list-style-type: none"> • AF Sound: Set the sound the camera emits when you half-press the shutter button on or off. (Off, On*) • Button Sound: Set the sound the camera emits when you press the buttons or touch the screen on or off. (Off, On*) • E-Shutter Sound: Set to emit a sound when you use the electronic shutter. (Off*, On)
	 <ul style="list-style-type: none"> • The camera emits a sound only when the shutter speed is longer than 0.5 second. • This option may not be available in Smart mode.

Item	Description
	* Default
Quick View	<p>Set the Quick View time length—the amount of time the camera displays a photo immediately after you capture it. Select Hold+Focus Zoom to display the image after shooting with the focus area enlarged.</p> <p>(Off*, Hold+Focus Zoom, Hold, 1 sec, 3 sec, 5 sec)</p>
Display Adjust	<p>Adjust the display brightness, auto brightness setting, display color, or level gauge.</p> <ul style="list-style-type: none"> • Display Brightness: You can adjust the display brightness manually. • Auto Brightness: Turn auto brightness on or off. (Off, On*) • Display Color: You can adjust the display color manually. • Horizontal Calibration: Calibrate the level gauge. If the level gauge is not level, position the camera on the level surface, and then follow the on-screen instructions.
	 <ul style="list-style-type: none"> • You cannot access the Horizontal Calibration option in Playback mode. • You cannot calibrate the level gauge in portrait orientation.
Auto Display Off	<p>Set the display off time. The display turns off if you do not use the camera for the time you set.</p> <p>(Off, 30 sec*, 1 min, 3 min, 5 min, 10 min)</p>

* Default

Item	Description
Power Save	<p>Set power shut off time. The camera shuts off if you do not use it within the time you set. (30 sec, 1 min*, 3 min, 5 min, 10 min, 30 min)</p> <div style="background-color: #f0f0f0; padding: 10px;">  <ul style="list-style-type: none"> • The camera retains the power-off time setting even if you replace the battery. • Power Save does not work if the camera is connected to a computer or a TV or playing a slide show or a movie. • Power Save does not work when the camera is connected to a smart phone and Pro Suggest Market is in use. • This product reduces energy consumption by using features that save power. </div>
Help Guide Display	<ul style="list-style-type: none"> • Mode Help Guide: Set to display help text about the selected mode when changing shooting modes. (Off*, On) • Function Help Guide: Set to display help text about menus and functions. (Off*, On) <div style="background-color: #f0f0f0; padding: 10px;">  <p>Press [] to hide the help text.</p> </div>

* Default

Item	Description
Language	Set a language the camera shows on the display.
Date and Time	Set date, time, date format, and time zone. (Time Zone, Date Settings, Time Settings, Date Type, Time Type)
Video Out	<p>Set the video signal output to the appropriate system for your country when connecting the camera to an external video device, such as an HDMI-supported TV.</p> <ul style="list-style-type: none"> • NTSC: USA, Canada, Japan, Korea, Taiwan, Mexico, etc. • PAL (Supports only PAL B, D, G, H, or I): Australia, Austria, Belgium, China, Denmark, Finland, France, Germany, England, Italy, Kuwait, Malaysia, New Zealand, Singapore, Spain, Sweden, Switzerland, Thailand, Norway, etc.
Anynet+ (HDMI-CEC)	<p>When you connect the camera to an HDMI-supported TV that supports Anynet+ (HDMI-CEC), you can control the playback functions of the camera with the TV remote control.</p> <ul style="list-style-type: none"> • Off: You cannot control the play function of camera with the TV remote control. • On*: You can control the play function of camera with the TV remote control.

* Default

Item	Description
HDMI Output	<p>When you connect the camera to an HDMI-supported TV with an HDMI cable, you can change the resolution of the image.</p> <ul style="list-style-type: none"> • NTSC: Auto*, 1920 X 1080p, 1280 X 720p, 720 X 480p, 720 X 576p (activates only when PAL is selected)
File Name	<p>Set the method of creating file names.</p> <ul style="list-style-type: none"> • Standard*: SAM_XXXX.JPG (sRGB)/_SAMXXXX.JPG (Adobe RGB) • Date: <ul style="list-style-type: none"> - sRGB files - MMDDXXXX.JPG. For example, for a photo captured on Jan. 01, the file name would be 0101XXXX.jpg. - Adobe RGB files - _MDDXXXX.JPG for the months Jan through Sept. For the months Oct through Dec, the month number is replaced by the letters A (Oct.), B (Nov.), and C (Dec.). <p>For example, for a photo captured on Feb. 03, the file name would be _203XXXX.jpg. For a photo captured on Oct. 05, the file name would be _A05XXXX.jpg.</p>



* Default

Item	Description
File Number	<p>Set the method of numbering files and folders.</p> <ul style="list-style-type: none"> • Reset: After using the reset function, the next file name is started at 0001. • Series*: New file numbers continue the existing number sequence, even if you have installed a new memory card, formatted the card, or deleted all photos. <div style="background-color: #f0f0f0; padding: 10px; border: 1px solid #ccc;">  <ul style="list-style-type: none"> • The first folder name is 100PHOTO. If you have selected the sRGB color space and Standard file naming, the first file name is SAM_0001. • File name numbers are increased by 1 from SAM_0001 to SAM_9999. • Folder numbers are increased by 1 from 100PHOTO to 999PHOTO. • The maximum number of files that can be saved in one folder is 9,999. • File numbers are assigned according to DCF (Design rule for Camera File system) specifications. • If you change a file name (for example, on a computer), the camera will not be able to play the file. </div>
Folder Type	<p>Set the type of folder.</p> <ul style="list-style-type: none"> • Standard*: XXXPHOTO • Date: XXX_MMDD

* Default

Item	Description
Format	<p>Format the memory card. Formatting deletes all existing files including protected files. (No*, Yes)</p> <div style="border: 1px solid #ccc; background-color: #f9f9f9; padding: 5px;">  <p>Errors can occur if you use a memory card formatted by another brand of camera, a memory card reader, or a computer. Please format memory cards in the camera before using them to capture photos.</p> </div>
Bluetooth	<p>Set to connect your camera to a smart phone automatically via the Bluetooth feature. If the devices have previously been connected and you launch Samsung Camera Manager on the smart phone, they will connect via Bluetooth automatically. (Off*, On)</p>
Wi-Fi Network	<p>Set to connect to a Wi-Fi network. (Off*, On)</p>
My Smartphone	<p>View the model name and connection status of the connected smart phone. You can also edit or delete the registered smart phone.</p>
Bluetooth Auto Time Set	<p>Set to sync the camera's date and time with the smart phone when connecting the camera to a smart phone via Bluetooth. (Off*, On)</p>

* Default

Item	Description
Wi-Fi Privacy Lock	<p>Set to require a PIN when connecting the camera and a smart phone.</p> <ul style="list-style-type: none"> • PIN: Enter a PIN before connecting. • None*: Allow a connection without requiring a PIN. <div style="border: 1px solid #ccc; background-color: #f9f9f9; padding: 5px;">  <ul style="list-style-type: none"> • Connections will automatically be made without requiring a PIN when you use the NFC function. • PINs are automatically generated and renewed only when you reset the camera settings or update the firmware. • If you have previously connected your camera to a smart phone via a PIN, they will connect automatically. </div>
Sensor Cleaning	<ul style="list-style-type: none"> • Sensor Cleaning: Remove dust from the sensor. • Start-up Action: When on, the camera performs sensor cleaning each time you turn it on. (Off*, On) • Shut-down Action: When on, the camera performs sensor cleaning each time you turn it off. (Off*, On) <div style="border: 1px solid #ccc; background-color: #f9f9f9; padding: 5px;">  <p>As this product uses interchangeable lenses, the sensor can get dust on it when you change lenses. This can lead to dust particles appearing in the photos you capture. We recommend that you do not change lenses when you are in a particularly dusty area. Also, make sure to attach the lens cap to the lens when not using it.</p> </div>

Item	Description
Reset	<p style="text-align: right;">* Default</p> <ul style="list-style-type: none"> • Camera Menu*: Return the setup menu and shooting options to the factory defaults. • Key Mapping: Return the custom button functions to the factory defaults. • C Mode: Return the C mode settings to the factory defaults. • Bluetooth/Wi-Fi: Return the connection history, ID, and password of the Bluetooth and Wi-Fi functions to the factory defaults. • All: Return all settings to the factory defaults. (Date, time, language, and video output settings will not change.)

Item	Description
Device Information	<p style="text-align: right;">* Default</p> <p>View the firmware version of the body and the lens, the Wi-Fi MAC address, and Bluetooth MAC address, or update the firmware.</p> <ul style="list-style-type: none"> • Software Update: Update the firmware of the camera body or lens, or download the firmware via Wi-Fi. (Body Firmware, Lens Firmware, Download via Wi-Fi) <div style="border: 1px solid #ccc; padding: 10px; background-color: #f9f9f9;">  <ul style="list-style-type: none"> • You can update the firmware by connecting the camera to a computer and starting i-Launcher. For more details, refer to page 203. • You cannot run a firmware update without a fully charged battery. Recharge the battery fully before running a firmware update. • If you update the firmware, user settings and values will be reset. (Date, time, language, and video out will not change.) • Do not turn the camera off while the update is in progress. • Remaining storage on the memory card must be more than 1 GB to update the firmware via Wi-Fi. • The process of updating firmware via Wi-Fi may not be stable depending on the quality of the network connection. </div>
Open Source License	View open source licenses.



Chapter 6

Appendix

Get information about error messages, camera maintenance, using programs on a computer, firmware updates, troubleshooting tips, specifications, and glossary terms.

Error messages

When the following error messages appear, try these remedies.

Error messages	Suggested remedies
Lens is locked	The lens is locked. Rotate the lens counter-clockwise until you hear a click. (p. 54)
Card Error	<ul style="list-style-type: none"> • Turn off the camera, and then turn it on again. • Remove the memory card and insert it again. • Format the memory card.
Low Battery	Insert a charged battery or recharge the battery.
No Image File.	Capture photos or insert a memory card that contains photos.
File Error	Delete the damaged file or contact a service center.
Recording stopped. You can record again after the camera cools down.	Cool down the camera.
Memory Full	Delete unnecessary files or insert a new memory card.

Error messages	Suggested remedies
Card Locked	You can lock SD, SDHC, or SDXC cards to prevent files from being deleted. Unlock the card when shooting. (p. 190)
Unable to capture a photo because folder and file number on the memory card reached the maximum values. Reset the folder number?	File names do not match the DCF standard. Follow the on-screen instructions to reset the folder number.
Error 00	Turn off your camera and remount the lens. If the message still appears, contact a service center.
Error 01/02	Turn off your camera, remove the battery, and insert again. If the message still appears, contact a service center.

Maintaining the camera

Cleaning the camera

Camera lens and display

Use a brush to remove dust and wipe the lens gently with a soft cloth. If any dust remains, apply lens cleaning liquid to a piece of lens cleaning paper and wipe gently.

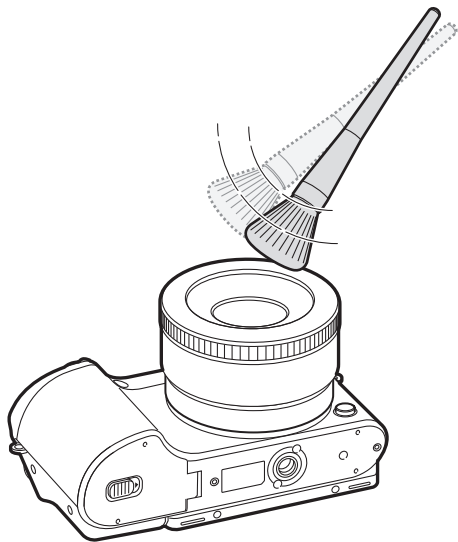

Image sensor

Depending on different shooting conditions, dust may appear in photos because the image sensor is exposed to the external environment. This problem is normal, and the exposure to dust occurs in everyday use of the camera. You can remove dust from the sensor by operating the sensor cleaning function. (p. 183) If dust remains after cleaning the sensor, contact a service center. Do not insert the blower into the opening of the lens mount.

Camera body

Wipe gently with a soft, dry cloth.



Never use benzene, thinners, or alcohol to clean the camera. These solutions can damage the camera or cause it to malfunction.

Using or storing the camera

Inappropriate places to use or store the camera

- Avoid exposing the camera to very cold or very hot temperatures.
- Avoid using your camera in areas with extremely high humidity, or where the humidity changes drastically.
- Avoid exposing the camera to direct sunlight and storing it in hot, poorly ventilated areas, such as in a car during summer time.
- Protect your camera and the display from impact, rough handling, and excessive vibration to avoid serious damage.
- Avoid using or storing your camera in dusty, dirty, humid, or poorly ventilated areas to prevent damage to moving parts and internal components.
- Do not use your camera near fuels, combustibles, or flammable chemicals. Do not store or carry flammable liquids, gases, or explosive materials in the same compartment as the camera or its accessories.
- Do not store the camera where there are mothballs.

Using on beaches or shores

- Protect your camera from sand and dirt when you use it on beaches or in other similar areas.
- Your camera is not waterproof. Do not handle the battery, adapter, or memory card with wet hands. Operating the camera with wet hands may cause damage to your camera.

Storing for an extended period of time

- When you store the camera for an extended period, place it in a sealed container with an absorbent material, such as silica gel.
- Over time, unused batteries will discharge and must be recharged before use.
- The present date and time must be re-entered if the camera is turned on after the camera and battery have been separated for a prolonged period.

Using the camera with caution in the humid environments

When you move the camera from a cold environment to a warm one, condensation can form on the lens or internal components of the camera. In this situation, turn off the camera and wait for at least 1 hour. If condensation forms on the memory card, remove the memory card from the camera and wait until all moisture has evaporated before reinserting it.

Other precautions

- Do not swing your camera by the strap. This may cause injury to yourself or others or damage to your camera.
 - Do not paint your camera, as paint can clog moving parts and prevent proper operation.
 - Turn off the camera when not using it.
 - Your camera consists of delicate parts. Avoid impacts to the camera.
 - Protect the display from damage by keeping it in the case when not in use. Protect the camera from scratches by keeping it away from sand, sharp objects, or loose change.
 - Do not use the camera if the screen is cracked or broken. Broken glass or acrylic could cause injury to your hands and face. Take the camera to a Samsung service center to have it repaired.
 - Never place cameras, batteries, chargers, or accessories near, on, or in heating devices, such as microwave ovens, stoves, or radiators. Heat can deform or overheat these devices, which can cause a fire or explosion.
- Do not expose the lens to direct sunlight, as this may discolor the image sensor or cause it to malfunction.
 - Protect your lens from fingerprints and scratches. Clean your lens with a soft, clean, debris-free lens cloth.
 - The camera may turn off if impacted from the outside. This is to protect the memory card. Turn on the camera to use it again.
 - While you use the camera, it may heat up. This is normal and should not affect your camera's lifespan or performance.
 - When you use the camera in low temperatures, it may take some time to turn on, the color of the display may be changed temporarily, or after-images may appear. These conditions are not malfunctions and they will correct themselves when the camera is returned to milder temperatures.
 - Paint or metal on the outside of the camera may cause allergies, itchy skin, eczema, or swelling for people with sensitive skin. If you experience any of these symptoms, stop using the camera immediately and consult a doctor.
 - Do not insert foreign objects into any of your camera's compartments, slots, or access points. Damage due to improper use may not be covered by your warranty.
 - Do not allow unqualified personnel to service the camera or attempt to service the camera yourself. Any damage that results from unqualified service is not covered by your warranty.

About memory cards

Supported memory cards

This product supports SD (Secure Digital), SDHC (Secure Digital High Capacity), SDXC (Secure Digital eXtended Capacity), microSD, microSDHC, or microSDXC memory cards.

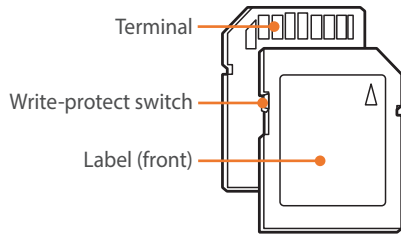

You can prevent files from being deleted by using the write-protect switch on an SD, SDHC, or SDXC card. Slide the switch down to lock or slide it up to unlock. Unlock the card when capturing photos and videos.

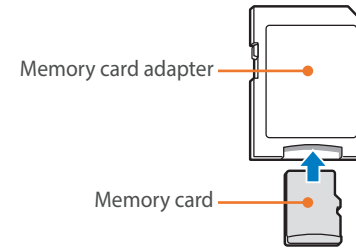

To use micro memory cards with this product, a PC, or a memory card reader, insert the card into an adapter.

Memory card capacity

The memory capacity may differ depending on the type of scenes you shoot and the shooting conditions. These capacities are based on a 4 GB SD card.

Size	Quality							
	Super Fine	Fine	Normal	RAW (Normal Compression)	RAW (Lossless Compression)	RAW (Lossless Compression) + S.Fine	RAW (Lossless Compression) + Fine	RAW (Lossless Compression) + Normal
28M (6480X4320)	256	471	810	102	64	51	57	60
13.9M (4560X3040)	475	815	1,270	-	-	58	61	63
7.1M (3264X2176)	801	1,253	1,744	-	-	62	64	65
3M (2112X1408)	1,379	1,863	2,259	-	-	65	65	66
Burst	806	1,259	1,750	-	-	-	-	-
23.6M (6480X3648)	299	542	911	-	-	53	58	61
Photo 11.9M (4608X2592)	537	905	1,376	-	-	59	62	63
6.2M (3328X1872)	879	1,346	1,832	-	-	63	64	65
2.4M (2048X1152)	1,545	2,008	2,363	-	-	65	66	66
18.7M (4320X4320)	368	653	1,064	-	-	56	60	62
9.5M (3088X3088)	642	1,050	1,537	-	-	61	63	64
4.7M (2160X2160)	1,064	1,553	2,015	-	-	64	65	65
2M (1408X1408)	1,668	2,109	2,431	-	-	65	66	66

	Size	Quality		
		Pro	HQ	Normal
Video	4096X2160 (24p/NTSC, PAL)	Approx. 7' 30"	Approx. 13' 6"	Approx. 16' 23"
	3840X2160 (30p/NTSC, 25p/PAL)	Approx. 7' 30"	Approx. 13' 6"	Approx. 16' 23"
	1920X1080 (60p/NTSC, 50p/PAL)	Approx. 7' 30"	Approx. 14' 9"	Approx. 27' 31"
	1920X1080 (30p/NTSC, 25p/PAL)	Approx. 8' 45"	Approx. 20' 54"	Approx. 40' 4"
	1920X1080 (24p/NTSC, PAL)	Approx. 8' 45"	Approx. 20' 54"	Approx. 40' 4"
	1920X1080 (15p/NTSC, 12.5p/PAL)*	Approx. 17' 26"	Approx. 39' 52"	Approx. 73' 41"
	1280X720 (120p/NTSC, 100p/PAL)	-	Approx. 17' 26"	Approx. 34' 47"
	1280X720 (60p/NTSC, 50p/PAL)	-	Approx. 27' 25"	Approx. 57' 35"
	1280X720 (30p/NTSC, 25p/PAL)	-	Approx. 39' 52"	Approx. 85' 39"
	640X480 (60p/NTSC, 50p/PAL)	-	Approx. 73' 2"	Approx. 167' 8"
	640X480 (30p/NTSC, 25p/PAL)	-	Approx. 124' 58"	Approx. 244' 43"
	640X480 (MJPEG, 30p/NTSC)	-	Approx. 34' 27"	Approx. 42' 3"
	640X480 (MJPEG, 25p/PAL)	-	Approx. 40' 34"	Approx. 49' 19"

* This option is available only with some Smart Filter options.

- The figures above are measured without using the zoom function.
- Available recording time may vary if you use the zoom function.
- Several videos were recorded in succession to determine the total recording time.
- The maximum recording time is 29 minutes and 59 seconds.
(When you select 1920X1080 (60p/50p), the maximum recording time is 25 minutes. When you select 4096X2160, 3840X2160, or 640X480 (MJPEG), the maximum recording time is 15 minutes.)

Cautions when using memory cards

- Avoid exposing memory cards to very cold or very hot temperatures (below 0 °C/32 °F or above 40 °C/104 °F). Extreme temperatures can cause memory cards to malfunction.
- Insert a memory card in the correct direction. Inserting a memory card in the wrong direction may damage your camera and memory card.
- Do not use memory cards that have been formatted by other cameras or by a computer. Reformat the memory card with your camera.
- Turn off the camera when you insert or remove the memory card.
- Do not remove the memory card or turn off your camera while the lamp is blinking, as this may damage your data.
- When the lifespan of a memory card has expired, you cannot store any more photos on the card. Use a new memory card.
- Do not bend, drop, or subject memory cards to heavy impact or pressure.
- Avoid using or storing memory cards near strong magnetic fields.
- Avoid using or storing memory cards in very hot, very humid, or corrosive environments.
- Prevent memory cards from making contact with liquids, dirt, or foreign substances. If dirty, wipe the memory card clean with a soft cloth before you insert the memory card into your camera.
- Do not allow liquids, dirt, or foreign substances to come in contact with memory cards or the memory card slot. Doing so may cause memory cards or the camera to malfunction.
- When you carry a memory card, use a case to protect the card from electrostatic discharges.
- Transfer important data to other media, such as a hard disk, CD, or DVD.
- When you use the camera for an extended period, the memory card may become warm. This is normal and does not indicate a malfunction.
- Use a memory card that meets the standard requirements.



The manufacturer is not responsible for any loss of data.

About the battery

Use only Samsung-approved batteries.

Battery specifications

Item	Description
Model	BP1130
Type	Lithium-ion battery
Cell capacity	1,130 mAh
Voltage	7.6 V
Charging time* (When the battery is completely discharged.)	Approx. 200 min.

*The figures above are based on using the provided USB cable and AC adaptor. Charging the battery by connecting it to a computer may take longer.



Personal injury or death can occur if the battery is handled carelessly or improperly. For your safety, follow these instructions for proper battery handling:

- The battery can ignite or explode if not handled properly. If you notice any deformities, cracks, or other abnormalities in the battery, immediately discontinue use of the battery and contact your manufacturer.
- Use only authentic, manufacturer-recommended battery chargers and charge the battery only by the method described in this user manual.
- Do not place the battery near heating devices or expose to excessively warm environments, such as the inside of an enclosed car in the summertime.
- Do not place the battery in a microwave oven.

- Avoid storing or using the battery in hot, humid places, such as spas or shower enclosures.
- Do not rest the camera on flammable surfaces, such as bedding, carpets, or electric blankets for a prolonged period.
- When the camera is switched on, do not leave it in any confined space for a prolonged period.
- Do not allow battery terminals to come in contact with metallic objects, such as necklaces, coins, keys, or watches.
- Use only authentic, manufacturer-recommended, Lithium-ion replacement batteries.
- Do not disassemble the battery or puncture it with any sharp object.
- Avoid exposing the battery to high pressure or crushing forces.
- Avoid exposing the battery to major impacts, such as dropping it from high places.
- Do not expose the battery to temperatures of 60 °C (140 °F) or above.
- Do not allow the battery to come in contact with moisture or liquids.
- Do not expose the battery to sources of excessive heat such as direct sunshine or fire.

Disposal guidelines

- Dispose of the battery with care.
- Do not dispose of the battery in a fire.
- Disposal regulations may differ by country or region. Dispose of the battery in accordance with all local and federal regulations.

Guidelines for charging the battery

Charge the battery only by the method described in this user manual. The battery can ignite or explode if not charged properly.

Battery life

Shooting mode	Average time/Number of photos
Photos	Approx. 185 min./Approx. 370 photos
Videos	Approx. 100 min. (Record videos at 1920X1080 (60p))

- The figures above are based on CIPA test standards. Your results may differ depending on your actual usage.
- Available shooting time differs depending on background, shooting interval, and use conditions.
- Several videos were recorded in succession to determine the total recording time.

Low battery message

When the battery has fully discharged, the battery icon will turn red and the “**Low Battery**” message will appear.

Notes about using the battery

- Avoid exposing batteries to very cold or very hot temperatures (below 0 °C/32 °F or above 40 °C/104 °F). Extreme temperatures can reduce the charging capacity of your batteries.
- When you use the camera for an extended period, the area around the battery chamber may become warm. This does not affect the normal use of the camera.
- Do not pull the power supply cord to disconnect the plug from the power outlet, as this may cause a fire or electric shock.
- In temperatures below 0 °C/32 °F, battery capacity and battery life may decrease.
- Battery capacity may decrease in low temperatures, but will return to normal in milder temperatures.
- Remove the batteries from your camera when storing it for an extended period. Installed batteries may leak or corrode over time and cause serious damage to your camera. Storing the camera for extended periods with the battery installed causes the battery to discharge. You may not be able to recharge a fully discharged battery.
- When you do not use the camera for an extended period (3 months or more), check the battery and recharge it regularly. If you let the battery discharge continually, its capacity and life may decrease, which can lead to a malfunction, fire, or explosion.

Battery precautions

Protect batteries, chargers, and memory cards from damage.

Prevent batteries from making contact with metal objects, as this can create a connection between the + and – terminals of your battery and lead to temporary or permanent battery damage and may cause a fire or electric shock.

Notes about charging the battery

- If the status lamp is off, ensure that the battery is inserted correctly.
- If the camera is on while the battery is charging, the battery may not fully charge. Turn off the camera before charging the battery.
- Do not use your camera when you are charging the battery. This may cause a fire or electric shock.
- Do not pull the power supply cord to disconnect the plug from the power outlet, as this may cause a fire or electric shock.
- Let the battery charge for at least 10 minutes before turning on the camera.
- If you connect the camera to an external power source when the battery is depleted, using high energy-consuming functions will cause the camera to turn off. To use the camera normally, recharge the battery.
- If you reconnect the power cable when the battery is fully charged, the status lamp turns on for approximately 30 minutes.
- Using the flash or recording videos depletes the battery quickly. Charge the battery fully before using the camera.
- If the status lamp blinks in red, reconnect the cable, or remove the battery and insert it again.
- If you charge the battery when the cable is overheated or the temperature is too high, the status lamp may blink in red. Charging will start when the battery cools down.
- Overcharging batteries may shorten battery life. After charging is finished, disconnect the cable from your camera.
- Do not bend or place heavy objects on the AC cable. Doing so may damage the cable.
- If you use the camera for an extended period while connected to an external power cable, the status lamp may blink red and green. The camera may also stop charging to protect the battery from being overcharged. Reconnect the cable and fully charge the battery before using the camera again.

Notes about charging with a computer connected

- Use only the provided USB cable.
- The battery may not charge when:
 - You use a USB hub.
 - Other USB devices are connected to your computer.
 - You connect the cable to the port on the front side of your computer.
 - The USB port of your computer does not support the power output standard (5 V, 500 mA).

Handle and dispose of batteries and chargers with care

- Never dispose of batteries in a fire. Follow all local regulations when you dispose of used batteries.
- Never place batteries or cameras on or in heating devices, such as microwave ovens, stoves, or radiators. Batteries may explode when they are overheated.



Using programs on a PC

You can view and edit files using the provided programs. You can also send the files to a PC wirelessly.

Installing i-Launcher

- 1 Turn off the camera.
- 2 Connect the camera to the PC with the USB cable.

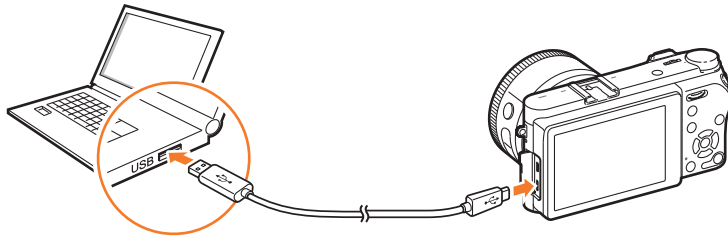

- You must plug the small end of the USB cable into your camera. If the cable is reversed, it may damage your files. The manufacturer is not responsible for any loss of data.
- If you try to plug the USB cable into the HDMI port, the camera may not work properly.

- 3 Turn on the camera.
- 4 Install i-Launcher on the PC.

OS	How to Install
Windows	<p>When the pop-up window prompts you to install i-Launcher, select Yes.</p> <ul style="list-style-type: none"> • If the pop-up window does not appear, select My Computer → i-Launcher → iLinker.exe. • If a pop-up window prompting you to run iLinker.exe appears, run it first. • When you connect the camera to a computer with i-Launcher installed, the program will launch automatically.
Mac	Click Devices → i-Launcher → Mac → iLinker.app .

- 5 Follow the on-screen instructions to install i-Launcher.
 - Available programs may differ depending on your computer's specifications.



Before installing the program, ensure that the PC is connected to a network.

Requirements for Windows OS

Item	Requirements
CPU	Intel® 3rd Gen. i5 3.4 GHz or higher (or equivalent AMD processor)
RAM	Minimum 1 GB RAM
OS	Windows 7, Windows 8, Windows 8.1
Hard disk capacity	400 MB (1 GB or higher recommended)
Others	USB 2.0 port

* Full HD is supported only on 32-bit editions. .NET Framework 4.0 or above is supported by Windows 7.



- The requirements on this page and the following pages are recommendations only. i-Launcher may not work properly even when the computer meets the requirements, depending on the condition of your computer.
- If your computer does not meet the requirements, videos may not play correctly.



The manufacturer is not responsible for any damage that results from using unqualified computers such as a computer you assembled yourself.

Requirements for Mac OS

Item	Requirements
OS	Mac OS 10.7 or higher
RAM	Minimum 256 MB RAM (512 MB or higher recommended)
Hard disk capacity	Minimum 110 MB
Others	USB 2.0 port

Using i-Launcher

i-Launcher allows you to update the firmware of the camera or the lens, or download the User Manual. It also allows you to download and install Samsung Movie Converter, Samsung DNG Converter, PC Auto Backup, Samsung RAW Converter, and the Power Media Player program.

Opening i-Launcher

Select **Start** → **All Programs** → **Samsung** → **i-Launcher** → **Samsung i-Launcher** on your computer. Or, click **Applications** → **Samsung** → **i-Launcher** on your Mac OS computer.

Available programs

Item	Description
Software Update	Download the firmware of the camera body or lens. For information about updating the firmware, refer to page 203.
Manual Download	Download the User Manual.
Samsung Movie Converter	Download this program to convert HEVC files to another format. You can convert HEVC files to other formats (H.264) and edit them in programs that are incompatible with HEVC. Converting UHD videos is supported only on 64-bit editions.
Samsung DNG Converter	Download this program to convert Samsung RAW files (SRW) to DNG files.
PC Auto Backup	i-Launcher provides a link for downloading the PC Auto Backup program when you connect the camera to a computer. You can send photos or videos that you captured with the camera to a PC wirelessly. For information about installing PC Auto Backup, refer to page 165.
Samsung RAW Converter	Download this program to convert RAW files into the desired file format.
Power Media Player	Download this program to play videos in HEVC or H.264 format. This program can be used only with Windows OS.

Requirements

Item	Requirements	
PC Auto Backup	Windows	Windows 7/8/8.1
	Mac	Mac OS 10.7 or higher
Samsung Movie Converter	Windows	64-bit Windows 7/8/8.1 (32-bit editions support up to Full HD. .NET Framework 4.0 or above is supported by Windows 7.)
	Mac	Mac OS 10.7 or higher
Power Media Player	Windows	Windows 7/8/8.1 Intel® 3rd Gen. i5 3.4 GHz or higher (equivalent AMD processor) Minimum 1 GB RAM 400 MB of available hard-disk space (1 GB and above recommended)
Samsung DNG Converter	Windows	Windows 7/8/8.1
	Mac	Mac OS 10.7/10.8/10.9/10.10

Item	Requirements	
Samsung RAW Converter	Windows	Windows 7/8/8.1 Intel Pentium/AMD Athlon processor-based PC or compatible computer (Core 2 Quad or later is recommended) 1 GB or higher is recommended XGA (1024X768), Full Color (24-bit or higher)
	Mac	Apple® Mac® OS X v10.7/10.8/10.9/10.10 Intel Pentium processor ready (Core 2 Quad or later is recommended) XGA or higher 16-bit color display compatible (24-bit or higher)

Installing Samsung RAW Converter

Launch i-Launcher, and then follow the on-screen instructions to install the program.

Using Samsung RAW Converter

Photos captured by a camera are often converted to JPEG format and stored in the memory according to the settings of the camera at the time of shooting. RAW files are not converted to JPEG format and are stored in the memory without any changes. With Samsung RAW Converter, you can calibrate exposures, White Balances, tones, contrasts, and colors of photos. You can also edit JPEG or TIFF files as well as RAW files. For more information, refer to the program guide.



- Depending on your version of Samsung RAW Converter, you may not be able to open RAW files. If this occurs, update the program.
- In Samsung RAW Converter, an image's brightness, color, and other effects may be displayed differently. This occurs because the original camera settings and options applied during image capture are removed to prepare the image for processing by Samsung RAW Converter.

Updating the firmware

Use Wi-Fi or a USB cable to connect the camera to the computer and update the firmware of the camera or the lens.



- You cannot run a firmware update without a fully charged battery. Recharge the battery fully before running a firmware update.
- If you update the firmware, user settings and values will be reset. (Date, time, language, and video out will not change.)
- Do not turn the camera off while the update is in progress.

Connecting via USB cable

- 1 Turn off the camera.
- 2 Connect your camera to the computer with the USB cable.

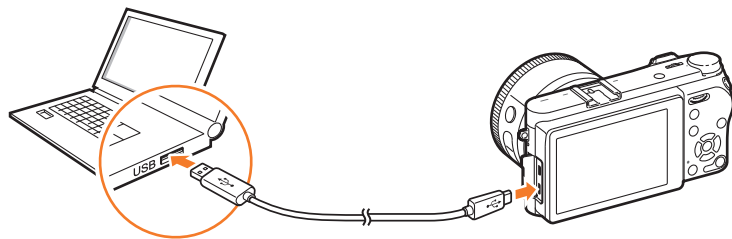

- You must plug the small end of the USB cable into your camera. If the cable is reversed, it may damage your files. The manufacturer is not responsible for any loss of data.
- If you try to plug the USB cable into the HDMI port, the camera may not work properly.

- 3 Turn on the camera.
- 4 On the computer, select **i-Launcher** → **Software Update**. (p. 200)
- 5 Follow the on-screen instructions to download the firmware to the camera.
 - You can download the firmware of the camera or the lens.
- 6 Turn off the camera when the download completes.
- 7 Remove the USB cable.
- 8 Turn on the camera.
- 9 Press [MENU] → ⚙️ → **Device Information** → **Software Update** → **Body Firmware** or **Lens Firmware**.
- 10 Select **Update** in the pop-up window on the camera to update the firmware.

Connecting via Wi-Fi

1 Press [MENU] → ⚙️ → **Device Information** → **Software Update** → **Download via Wi-Fi**.

- The camera will automatically attempt to connect to a WLAN via the most recently connected AP device.
- If the camera has not previously been connected to a WLAN, it will search for available AP devices. (p. 153)

2 Select **Download** in the pop-up window.

- If a firmware already downloaded is available, select **OK** in the pop-up window.

3 Select **OK** in the pop-up window on the camera to update the firmware.



- Remaining storage on the memory card must be more than 1 GB to update the firmware via Wi-Fi.
- Updating firmware via Wi-Fi may not be stable depending on the quality of the network connection.



Before contacting a service center

If you are having trouble with your device, try these troubleshooting solutions before contacting a service professional.



When you leave your camera at a service center, be sure to also leave the other components that may have contributed to the malfunction, such as the memory card and battery.

Situation	Suggested remedies
Cannot turn on the camera	<ul style="list-style-type: none"> • Ensure that the battery is inserted. • Ensure that the battery is inserted correctly. • Charge the battery.
The power turns off suddenly	<ul style="list-style-type: none"> • Charge the battery. • Your camera may be in Power save mode or the display turns off automatically. (p. 181) • The camera may be turned off automatically to prevent the memory card from being damaged due to excessive heat. Turn on your camera again.
The camera is losing battery power quickly	<ul style="list-style-type: none"> • The battery may lose power more quickly in low temperatures (below 0 °C/32 °F). Keep the battery warm by putting it into your pocket. • Using the flash or recording videos depletes the battery quickly. Recharge if needed. • Batteries are consumable parts that must be replaced over time. Get a new battery if the battery life is diminishing quickly.

Situation	Suggested remedies
Cannot capture photos	<ul style="list-style-type: none"> • There is no space on the memory card. Delete unnecessary files or insert a new card. • Format the memory card. • The memory card is defective. Get a new memory card. • The memory card is locked. Unlock the card. (p. 190) • Ensure that the camera is switched on. • Charge the battery. • Ensure that the battery is inserted correctly.
The camera freezes	Remove the battery and insert it again.
The camera heats up	While using the camera, it may heat up. This is normal and should not affect your camera's lifespan or performance.
The flash fires unexpectedly	The flash may fire due to static electricity. The camera is not malfunctioning.
The flash does not work	<ul style="list-style-type: none"> • The flash option may be set to Off. (p. 106) • You cannot use the flash in some modes.
The date and time are incorrect	Set the date and time under the ⚙️ menu. (p. 181)
The display or buttons do not work	Remove the battery and insert it again.

Situation	Suggested remedies
The memory card has an error	<ul style="list-style-type: none"> • Turn off the camera, and then turn it on again. • Remove the memory card, and then insert it again. • Format the memory card. <p>See “Cautions when using memory cards” for more details. (p. 193)</p>
Your computer does not recognize an SDXC or UHS-I/UHS-II memory card	<p>SDXC memory cards use the exFAT file system. To use SDXC memory cards or UHS-I/UHS-II memory cards that are formatted with the exFAT file system on a Windows XP computer, download and update the exFAT file system driver from the Microsoft website.</p>
Your TV or computer cannot display photos and videos that are stored on an SDXC or UHS-I/UHS-II memory card	<p>SDXC memory cards use the exFAT file system. To use SDXC memory cards or UHS-I/UHS-II memory cards that are formatted with the exFAT file system, ensure that the external device is compatible with the exFAT file system before connecting the camera to the device.</p>
Cannot display files	<p>If you change the name of a file, your camera may not play the file (the name of the file should meet the DCF standard). If you encounter this situation, display files on your computer.</p>

Situation	Suggested remedies
The photo is blurry	<ul style="list-style-type: none"> • Ensure that the focus option you set is suitable for the kind of shot you are capturing. • Use a tripod to prevent your camera from shaking. • Ensure that the lens is clean. If not, clean the lens. (p. 187)
The colors in the photo do not match the actual scene	<p>An incorrect White Balance can create unrealistic color. Select the proper White Balance option to suit the light source. (p. 83)</p>
The photo is too bright or too dark.	<p>Your photo is overexposed or underexposed.</p> <ul style="list-style-type: none"> • Adjust the aperture value or the shutter speed. • Adjust the ISO sensitivity. (p. 80) • Turn the flash off or on. (p. 106) • Adjust the exposure value. (p. 115)
Photos are distorted	<p>Minor distortion can occur when you use this camera with a wide angle lens that lets the camera take pictures with a wide angle of view. This is normal, and is not a malfunction.</p>
Horizontal lines appear on the photo	<p>This may occur when the subject is illuminated by a fluorescent or mercury-vapor light source. Select a slow shutter speed.</p>

Situation	Suggested remedies
The playback screen does not appear on the connected external device	<ul style="list-style-type: none"> • Ensure that the HDMI cable is properly connected to the external monitor. • Ensure that the memory card has recorded properly.
Your computer does not recognize your camera	<ul style="list-style-type: none"> • Ensure that the USB cable is connected correctly. • Ensure that the camera is switched on. • Ensure that you are using a supported operating system.
Your computer disconnects the camera while transferring files	The file transfer may be interrupted by static electricity. Disconnect the USB cable and connect it again.
i-Launcher is not functioning properly	<ul style="list-style-type: none"> • End i-Launcher and restart the program. • Depending on your computer's specifications and environment, the program may not launch automatically. If this occurs, click Start → All Programs → Samsung → i-Launcher → Samsung i-Launcher on your Windows computer. (For Windows 8, open the Start screen, and then select All apps → Samsung i-Launcher) Or, click Applications → Samsung → i-Launcher or i-Launcher Assistant on your Mac OS computer.

Situation	Suggested remedies
Auto Focus does not work	<ul style="list-style-type: none"> • The subject is not in focus. When the subject is outside the AF area, focus on the subject by moving it into the AF area and half-pressing [Shutter]. • The subject is too close. Step back from the subject and shoot. • The focus mode is set to MF. Switch the mode to AF.
The AEL feature does not work	The AEL feature does not work in AUTO , M , and S modes. Select another mode to use this feature.
The lens does not work	<ul style="list-style-type: none"> • Ensure that the lens is properly mounted. • Remove the lens from the camera and remount it.
The external flash does not work	Ensure that the external device is properly mounted and turned on.
The date and time settings screen appears when you power on the camera	<ul style="list-style-type: none"> • Set the date and time again. • This screen appears when the camera's internal power source has completely discharged. Insert a fully charged battery, turn off the camera, and then wait at least 72 hours for the internal power source to recharge.

Camera specifications

Image Sensor	
Type	BSI CMOS
Sensor size	23.5 X 15.7 mm
Effective pixels	Approx. 28.2 mega-pixels
Total pixels	Approx. 30.7 mega-pixels
Color filter	RGB primary
Lens Mount	
Type	Samsung NX Mount
Image Stabilization	
Type	Lens shift (depends on lens)
i-Function	
Features	Aperture value, Shutter speed, Exposure value, ISO, White Balance, intelli-Zoom
Dust Reduction	
Supersonic drive	
Display	
Type	Super AMOLED with Touch Screen
Size	3.0" (Approx. 76.6 mm)
Resolution	1,036 k dots

Field of view	Approx. 100 %
Angle	Flip (Up 180°), Tilt (Up 90°, Down 45°)
Focusing	
Type	Hybrid AF
Focusing point	205 points (Phase Detection AF), 209 points (Contrast AF)
Mode	Active AF, Single AF, Continuous AF, Manual Focus
Shutter	
Speed	<ul style="list-style-type: none"> • Auto: 1/6,000 sec.–1/4 sec. • Manual: 1/6,000 sec.–30 sec. • Bulb (time limit: 8 min.)
Exposure	
Metering system	TTL 221 Block segment
Compensation	Still: ±5 EV, Movie: ±3 EV (1/3 EV Step)
ISO equivalent	Auto, 100–25600 (1 EV or 1/3 EV Step) * You can expand up to ISO 51200.

Drive Modes	
Mode	Single, Continuous, Timer, Bracket
Continuous shooting	9 fps * Maximum shooting speed is 9 frames per second. It will slow down after approx. JPEG 40 shots, RAW 5 shots. (Based on UHS-I SD Card. May vary depending on the spec of memory card.)
Bracket shooting	Auto exposure bracketing, White Balance bracketing, Picture Wizard bracketing, Depth bracketing
Self-timer	2–30 sec. (1 second interval)
Flash	
Type	External Flash (bundle with SEF8A)
Mode	Smart Flash, Auto, Auto Red-eye, Fill-in, Fill-in Red, 1st Curtain, 2nd Curtain, Off
Guide number	8 (based on ISO 100)
Sync speed	Less than 1/200 sec.
White Balance	
Mode	Auto WB, Daylight, Cloudy, Fluorescent White, Fluorescent NW, Fluorescent Daylight, Tungsten, Tungsten (Auto), Flash WB, Custom Set, Color Temperature (Manual)

Dynamic Range Expansion	
Off/Smart Range+/HDR	
Effects	
Picture wizard	Standard, Vivid, Portrait, Landscape, Forest, Retro, Cool, Calm, Classic, Custom1, Custom2, Custom3
Smart filter	Vignetting, Miniature (H), Miniature (V), Watercolor, Selective Color (R/G/B/Y 4 Colors)
Photos	
Mode	Auto, Program, Aperture Priority, Shutter Priority, Manual, Custom, Samsung Auto Shot, Smart
Smart mode	Beauty Face, Landscape, Action Freeze, Rich Tones, Panorama, Waterfall, Silhouette, Sunset, Night, Fireworks, Light Trace, Multi Exposure
Size-JPEG	<ul style="list-style-type: none"> • (3:2): 28M (6480X4320), 13.9M (4560X3040), 7.1M (3264X2176), 3M (2112X1408) • (16:9): 23.6M (6480X3648), 11.9M (4608X2592), 6.2M (3328X1872), 2.4M (2048X1152) • (1:1): 18.7M (4320X4320), 9.5M (3088X3088), 4.7M (2160X2160), 2M (1408X1408)
Size-RAW	28M (6480X4320)
RAW format	SRW (Compression: Lossless Compression, Normal Compression)
Color space	sRGB, Adobe RGB

Video	
Format	MP4, AVI
Compression Video	HEVC, MJPEG (VGA only)
Size	4096X2160 (24 fps), 3840X2160 (30 fps), 1920X1080, 1280X720, 640X480 * When recording 4K or UHD video, the angle of view becomes narrower. (Effective angle of view: approx. 4K 1.68 times, UHD 1.77 times the focal length)
Frame rate	<ul style="list-style-type: none"> • NTSC: 120 fps (HD only), 60 fps, 30 fps, 24 fps • PAL: 100 fps (HD only), 50 fps, 25 fps, 24 fps
Sound	Stereo
Storage	
External media	SD card, SDHC card, SDXC card (up to 64 GB guaranteed) (UHS-I supported)
File format	RAW, JPEG, MPO (3D)
Network and Wireless Connectivity	
Wi-Fi	IEEE 802.11b/g/n
NFC	Yes
Bluetooth	Yes

Interface	
Digital output connector	Yes (USB 2.0)
Video output	HDMI (NTSC, PAL)
Battery	
Capacity	1,130 mAh
Physical Specifications	
Dimensions (W X H X D)	4.7 X 2.5 X 1.7 in (119.5 X 63.6 X 42.5 mm, without protrusions)
Weight	Approx. 10 oz (292 g, body only)
Operating Temperature	0–40 °C
Operating Humidity	5–85 %
System Requirements	
Windows	Windows 7/8/8.1, Intel® 3rd Gen. i5 3.4 GHz or higher (equivalent AMD processor)
Macintosh	Mac OS 10.7 or higher

* Specifications may change without notice to improve performance.

* Other brands and products names are trademarks of respective owners.

Anaglyph mode

Anaglyph mode enables a 3D effect to be applied to images when they are viewed through optical devices such as special glasses. The camera captures two separate images in red and cyan (chromatically opposite colors). The images are combined and when viewed through special glasses, with red and cyan colored filters, a 3D effect is achieved.

AP (Access Point)

An access point is a device that allows wireless devices to connect to a wired network.

Ad-Hoc network

An ad-hoc network is a temporary connection for sharing files or an internet connection and between computers and devices.

Adobe RGB

Adobe RGB is used for commercial printing and has a larger color range than sRGB. Its wider range of colors helps you easily edit photos on a computer.

AEB (Auto Exposure Bracket)

This feature automatically captures several images at different exposures to help you capture a properly-exposed image.

AEL/AFL (Auto Exposure Lock/Auto Focus Lock)

These features help you to lock the exposure or focus settings for a subject.

AF (Auto Focus)

A system that automatically focuses the camera lens on the subject. Your camera uses contrast to focus automatically.

AMOLED (Active-matrix organic light-emitting diode)/ LCD (Liquid Crystal Display)

AMOLED is a very thin and light visual display that does not require backlighting. LCD is a visual display commonly used in consumer electronics. An LCD display needs a separate backlight, such as CCFL or LED lights, to reproduce colors.

Aperture

The aperture controls the amount of light that reaches the camera's sensor.

Bluetooth

This feature allows you to exchange files with other devices.

Camera shake (Blur)

If the camera is moved while the shutter is open, the entire image may appear blurred. This occurs more often when the shutter speed is slow. Prevent camera shake by raising the ISO sensitivity, using the flash, or using a faster shutter speed. Alternatively, use a tripod or the OIS function to stabilize the camera.

Cloud Computing

Cloud computing is a technology that allows you to store data on remote servers and to use it from a device with Internet access.

Color space

The range of colors that the camera can identify and reproduce in photos.

Color temperature

Color Temperature is a measurement in degrees Kelvin (K) that indicates the hue of a specific type of light source. As the color temperature increases, the color of the light source has a more bluish quality. As the color temperature decreases, the color of the light source has a more reddish quality. At 5,500 degrees Kelvin, the color of the light source is similar to the sun at midday.

Composition

Composition in photography means arranging objects in a photo. Usually, abiding by the rule of thirds leads to a good composition.

DCF (Design rule for Camera File system)

A specification that defines a file format and file system for digital cameras created by the Japan Electronics and Information Technology Industries Association (JEITA).

Depth of field

The distance between the nearest and farthest points that can be acceptably focused in a photograph. Depth of field varies with lens aperture, focal length, and distance from the camera to the subject. Selecting a smaller aperture value, for example, will increase the depth of field and blur the background of a composition.

Electronic first curtain shutter

The sensor acts as the first curtain of the shutter. With this function, the shutter reacts faster because no process is needed to operate the mechanical curtain.

EV (Exposure Value)

All the combinations of the camera's shutter speed and lens aperture that result in the same exposure.

EV Compensation

This feature allows you to quickly adjust the exposure value measured by the camera, in limited increments, to improve the exposure of your photos.

Exif (Exchangeable Image File Format)

A specification that defines an image file format for digital cameras created by the Japan Electronic Industries Development Association (JEIDA).

Exposure

The amount of light allowed to reach the camera's sensor. Exposure is controlled by a combination of the shutter speed, the aperture value, and ISO sensitivity.

Flash

A speed light that helps to create adequate exposure in low-light conditions.

Focal length

The distance from the middle of the lens to its focal point (in millimeters). Longer focal lengths result in narrower angles of view and the subject is magnified. Shorter focal lengths result in wider angles of view.

Histogram

A graphical representation of the brightness of an image. The horizontal axis represents the brightness and the vertical axis represents the number of pixels. High points at the left (too dark) and right (too bright) on the histogram indicate a photo that is improperly exposed.

HEVC

High-efficiency Video Coding format, established by the international standard organizations ISO-IEC and ITU-T. This codec is capable of providing good video quality at low bit rates.

Image sensor

The physical part of a digital camera that contains a photosite for each pixel in the image. Each photosite records the brightness of the light that strikes it during an exposure. Common sensor types are CCD (Charge-coupled Device) and CMOS (Complementary Metal Oxide Semiconductor).

IP (Internet protocol) address

An IP address is a unique number that is assigned to every device that is connected to the internet.

ISO sensitivity

The sensitivity of the camera to light, based on the equivalent film speed used in a film camera. At higher ISO settings, the camera can use a higher shutter speed to reduce blur caused by camera shake and low light. However, images with a high ISO setting are more susceptible to noise.

JPEG (Joint Photographic Experts Group)

A lossy method of compression for digital images. JPEG images are compressed to reduce their overall file size with minimal deterioration of the image resolution.

Metering

The metering refers to the way in which the camera measures the quantity of light to set the exposure.

MF (Manual Focus)

A system that manually focuses the camera lens on the subject. You can use the focus ring to focus on a subject.

MJPEG (Motion JPEG)

A video format which is compressed as a JPEG image.

MPO (Multi Picture Object)

An image file format that contains multiple images in a file. An MPO file provides a 3D effect on MPO-compatible displays, such as 3D TVs or 3D monitors.

Noise

Misinterpreted pixels in a digital image that may appear as misplaced or random, bright pixels. Noise usually occurs when photos are shot with a high ISO setting or when the ISO sensitivity is automatically set in a dark place.

NFC (Near Field Communication)

NFC is a set of standards for radio communication at very close proximity. You can use NFC-enabled devices to activate features or exchange data with other devices.

NTSC (National Television System Committee)

A video color encoding standard used most commonly in Japan, North America, the Philippines, South America, South Korea, and Taiwan.

Optical zoom

This is a general zoom which can enlarge images with a lens and does not reduce the quality of images.

PAL (Phase Alternate Line)

A video color encoding standard used in numerous countries throughout Africa, Asia, Europe, and the Middle East.

Quality

An expression of the rate of compression used in a digital image. Higher quality images have a lower rate of compression, which usually results in a larger file size.

RAW (CCD raw data)

The original, unprocessed data, collected directly from the camera's image sensor. White Balance, contrast, saturation, sharpness, and other data can be manipulated with editing software before the image is compressed into a standard file format.

Resolution

The number of pixels present in a digital image. High resolution images contain more pixels and typically show more detail than low resolution images.

Shutter speed

Shutter speed refers to the amount of time it takes to open and close the shutter. It is an important factor in the brightness of a photo, as it controls the amount of light which passes through the aperture before it reaches the image sensor. A fast shutter speed allows less time to let in light. The photo becomes darker, but subjects in motion freeze more easily.

sRGB (Standard RGB)

International standard of color space established by the IEC (International Electrotechnical Commission). This is the defined color space for PC monitors and is also used as the standard color space for Exif.

Vignetting

A reduction of an image's brightness or saturation at the periphery (outer edges) compared to the center of the image. Vignetting can draw interest to subjects positioned in the center of an image.

White Balance (Color balance)

An adjustment of the intensities of colors (typically the primary colors red, green, and blue), in an image. The goal of adjusting the White Balance, or color balance, is to correctly render the colors in an image.

Wi-Fi

Wi-Fi is a technology that allows electronic devices to exchange data wirelessly over a network.

WPS (Wi-Fi Protected Setup)

WPS is a technology that secures wireless home networks.

Optional accessories

You can purchase the following optional items:

Lens, external flash, shutter release (micro USB type), rechargeable battery, battery charger, camera bag, camera case, memory card, filter, USB cable, HDMI cable, and camera strap.



- For information about accessories and their availability, visit the Samsung website.
- Before purchasing accessories, make sure they are compatible with your camera.
- Use only Samsung-approved accessories. Samsung is not responsible for damage caused by using another manufacturer's accessories.



A

Accessories

- Connect the flash 59
- Flash layout 58

Active AF 89

AEL 117

Aperture 16, 20

Auto Backup 165

Auto focus 87

B

Battery

- Caution 194
- Charging 36
- Insert 34

Bluetooth Shutter 148

Bracketing 102

C

Camera

- Disconnecting (Windows) 168
- Layout 30

Camera specifications 208

Color space 172

Connecting to a computer

- Auto Backup 165
- Connecting as removable disk 167
- Mac OS 168
- Windows OS 167

Connecting to a smart phone

- Bluetooth Shutter 148
- MobileLink 144
- Quick Transfer 149
- Remote Viewfinder 146

Connecting to a TV

- 3DTV 164
- TV 163
- TV Link 161

Continuous shooting 101

D

Date and Time 181

Depth of Field (DOF) 17, 22

Display brightness 180

Display type 51

Drive 100

E

Email 157

Enlarging 131

Error messages 186

Exposure Value (EV) 16, 115

F

Fader 123

FEL 110

Files

- Deleting 130
- Extension 120
- Format 79
- Protecting 129

Flash

- Bounce photography 27
- Flash options 106
- Guide number 26
- Intensity 107

F-number 16

Focal length 21

Focus assist 96

Focus Peaking 98

I

Icons

- Playback mode 50
- Shooting mode 46

i-Launcher 198

Image adjustment

- Adjusting photos 139
- Retouching faces 139

Initial settings 37

Interval capture 105

ISO 19, 20, 80

L

Lenses

- Layout 53
- Locking 54
- Markings 57
- Unlocking 55

M

Maintenance 187

Memory card

- Caution 190
- Insert 34

Metering 111

MF Assist 96

MobileLink 144

N

NFC 142

Notification panel 52

O

One touch shot 95

Optical Image Stabilization (OIS) 99

Optional accessories 217

P

Panorama mode 72

Photos

- Editing 137
- Enlarging 131
- Shooting options 78
- Viewing on camera 126

Picture Wizard 85

Posture 13

Power save mode 181

Q

Quick Transfer 149

R

Red-eye effect 107

Remote Viewfinder 146

Resolution

- Playback mode 138
- Shooting mode (Movie) 119
- Shooting mode (Photo) 78

Rotating 138

Rule of thirds 24

S

Samsung RAW Converter 202

Service center 205

Settings 180

Shooting modes

Aperture Priority 64

Auto 60

Custom 67

Manual 66

Program 62

Recording 73

Samsung Auto Shot 69

Shutter Priority 65

Smart 71

Shutter speed 18, 20

Slide show 132

Smart filter

Playback mode 140

Shooting mode 86

Smart panel 42

Smart Range+ 124

T

Thumbnails 126

Time Lapse 105

Timer 102

Touch AF 94

Touch screen 40

Tracking AF 94

Transferring files

Mac 168

Windows 167

TV Link 161

U

Unpacking 29

V

Video Out 181

Videos

Capturing 136

Options 119

Recording 73

Viewing 134

W

White balance 83

Wireless network 153

3

3D mode 75



Please refer to the warranty that came with your product
or visit our website www.samsung.com for after-sales service or inquiries.

CE 0168